

- Product Update 1 – New innovative LB Dipole implemented, which improves gain and pattern performance in the MB arrays
- Product Update 2 – Product now utilizes Internally Daisy Chained Type 17 RETs
- Eight foot (2.4 m) DualBand, twelve port antenna with a 65° azimuth beamwidth covering 698-896 MHz and 1695-2400 MHz frequencies
- Eight wide mid band ports covering 1695-2400 MHz and four wide low band ports covering 698-896 MHz in a single antenna enclosure
- Full Spectrum Compliance 698-896 MHz / 1695-2400 MHz
- Innovative Low and Mid Band Array configuration allows for 4T4R (4x4 MIMO) on Low Band and Dual 4T4R (4x4 MIMO) Mid Band Arrays, using full length arrays (non stacked), all in a 20.7" (525mm) width enclosure, an Industry First
- LTE Optimized FBR and SPR performance, providing for an efficient use of valuable radio capacity
- LTE Optimized Boresight and Sector XPD and USL performance, essential for LTE Performance
- Exceeds minimum PIM performance requirements
- Equipped with new 4.3-10 connectors

Overview

The CCI 12-Port DualBand array is a twelve port antenna, with eight wide mid band ports covering 1695-2400 MHz and four wide low band ports covering 698-896 MHz. The antenna provides the capability to deploy Dual 4x4 Multiple-input Multiple-output (MIMO) in the mid band and 4x4 MIMO across low band ports. The CCI 12-Port mid band ports have independent tilt control between left and right antenna arrays.

In this three RET configuration, the 1st RET is dedicated for the four Low Band ports. The 2nd RET is dedicated for the four Left Mid Band ports and the 3rd RET is dedicated for the four Right Mid Band ports. This RET arrangement allows for complete flexibility in coverage control between left and right mid band antenna arrays.

CCI antennas are designed and produced to ISO 9001 certification standards for reliability and quality in our state-of-the-art manufacturing facilities.

Applications

- Dual 4x4 MIMO for the Mid Band and 4x4 MIMO Low Band ports
- Ready for Network Standardization on 4.3-10 DIN connectors
- With CCI's DualBand antennas, wireless providers can connect multiple platforms to a single antenna, reducing tower load, lease expense, deployment time and installation costs



DualBand Twelve-Port Antenna

TPA65R-BU8Dv2

SPECIFICATIONS

Electrical

Ports	4 x Low Band Ports for 698-896 MHz	
Frequency Range	698-806 MHz	824-896 MHz
Gain	15.5 dBi	16.5 dBi
Azimuth Beamwidth (-3dB)	73°	62°
Elevation Beamwidth (-3dB)	9.5°	7.9°
Electrical Downtilt	2° to 12°	2° to 12°
Elevation Sidelobes (1st Upper)	<-18 dB	<-19 dB
Front-to-Back Ratio @180°	> 35 dB	> 35 dB
Cross-Polar Discrimination at Peak	> 25 dB	> 25 dB
Cross-Polar Port-to-Port Isolation	> 25 dB	> 25 dB
Voltage Standing Wave Ratio (VSWR)	< 1.5:1	< 1.5:1
Passive Intermodulation (2x20W)	≤ -153 dBc	≤ -153 dBc
Input Power Continuous Wave (CW)	500 watts	500 watts
Polarization	Dual Linear 45°	Dual Linear 45°
Input Impedance	50 ohms	50 ohms
Lightning Protection	DC Ground	DC Ground

BASTA Electrical Specifications		
Frequency Range	698-806 MHz	824-896 MHz
Gain over all Tilts (dBi)	14.6	15.6
Gain over all Tilts Tolerance (dB)	0.8	0.5
Gain at Low-Tilt (dBi)	14.7	15.7
Gain at Mid-Tilt (dBi)	14.7	15.8
Gain at High-Tilt (dBi)	14.4	15.4
Azimuth Beamwidth Tolerance (°)	8.7	9.9
Elevation Beamwidth Tolerance (°)	1.0	0.5
Electrical Downtilt Deviation (°)	0.7	0.7
First Upper Sidelobe Suppression (dB)	13.8	14.1
Upper Sidelobe Suppression Peak to 20°(dB)	15.4	14.1
Front-to-Back Ratio over ±20° (dB)	24.5	28.7
Cross-polar Discrimination at ±60° (dB)	10.4	9.5

* Electrical specifications follow document "Recommendation on Base Station Antenna Standards" (BASTA) V11.1.
All specifications are subject to change without notice.



SPECIFICATIONS

DualBand Twelve-Port Antenna

TPA65R-BU8Dv2

Electrical

Ports	8 × Mid Band Ports for 1695-2400 MHz			
Frequency Range	1695-1880 MHz	1850-1990 MHz	1920-2180 MHz	2300-2400 MHz
Gain	17.7 dBi	18.2 dBi	18.5 dBi	18.6 dBi
Azimuth Beamwidth (-3dB)	69°	62°	61°	57°
Elevation Beamwidth (-3dB)	5.7°	5.1°	4.8°	4.0°
Electrical Downtilt	0° to 8°	0° to 8°	0° to 8°	0° to 8°
Elevation Sidelobes (1st Upper)	<-16 dB	<-17 dB	<-17 dB	<-17 dB
Front-to-Back Ratio @180°	> 35 dB	> 35 dB	> 35 dB	> 35 dB
Cross-Polar Discrimination at Peak	> 19 dB	> 17 dB	> 17 dB	> 18 dB
Cross-Polar Port-to-Port Isolation	> 25 dB	> 25 dB	> 25 dB	> 25 dB
Voltage Standing Wave Ratio (VSWR)	< 1.5:1	< 1.5:1	< 1.5:1	< 1.5:1
Passive Intermodulation (2x20W)	≤ -153 dBc	≤ -153 dBc	≤ -153 dBc	≤ -153 dBc
Input Power Continuous Wave (CW)	300 watts	300 watts	300 watts	300 watts
Polarization	Dual Linear 45°	Dual Linear 45°	Dual Linear 45°	Dual Linear 45°
Input Impedance	50 ohms	50 ohms	50 ohms	50 ohms
Lightning Protection	DC Ground	DC Ground	DC Ground	DC Ground

BASTA Electrical Specifications				
Frequency Range	1695-1880 MHz	1850-1990 MHz	1920-2180 MHz	2300-2400 MHz
Gain over all Tilts (dBi)	16.4	17.1	17.6	17.6
Gain over all Tilts Tolerance (dB)	0.7	0.8	0.7	0.9
Gain at Low-Tilt (dBi)	16.3	16.8	17.3	17.1
Gain at Mid-Tilt (dBi)	16.5	17.3	17.9	17.9
Gain at High-Tilt (dBi)	16.4	17.2	17.7	17.8
Azimuth Beamwidth Tolerance (°)	9.3	6.9	5.7	6.8
Elevation Beamwidth Tolerance (°)	0.4	0.3	0.4	0.2
Electrical Downtilt Deviation (°)	0.8	0.8	0.8	0.9
First Upper Sidelobes Suppression (dB)	12.0	13.2	12.7	14.4
Upper Sidelobe Suppression Peak to 20°(dB)	11.2	12.6	12.4	14.0
Front-to-Back Ratio over ±20° (dB)	27.8	28.3	28.7	27.4
Cross-polar Discrimination at ±60° (dB)	9.7	8.0	8.0	6.2

* Electrical specifications follow document "Recommendation on Base Station Antenna Standards" (BASTA) V11.1. All specifications are subject to change without notice.



SPECIFICATIONS

DualBand Twelve-Port Antenna

TPA65R-BU8Dv2

Mechanical

Dimensions (LxWxD)	96.0x20.7x7.7 in (2438x525x197 mm)
Survival Wind Speed	> 150 mph (> 241 kph)
Front Wind Load¹	342 lbf @ 100 mph 1521 N @ 161 kph
Side Wind Load¹	84 lbf @ 100 mph 375 N @ 161 kph
Effective Projective Area (EPA), Front¹	14.0 ft ² (1.3 m ²)
Weight *	90.4 lbs (41.0 kg)
RF Connector	12 x 4.3-10 female
Mounting Pole	2 to 5 in (5 to 12 cm)

¹Windload values calculated using CFD analysis
* Weight excludes mounting



SPECIFICATIONS

DualBand Twelve-Port Antenna

TPA65R-BU8Dv2

Mechanical

Bottom View

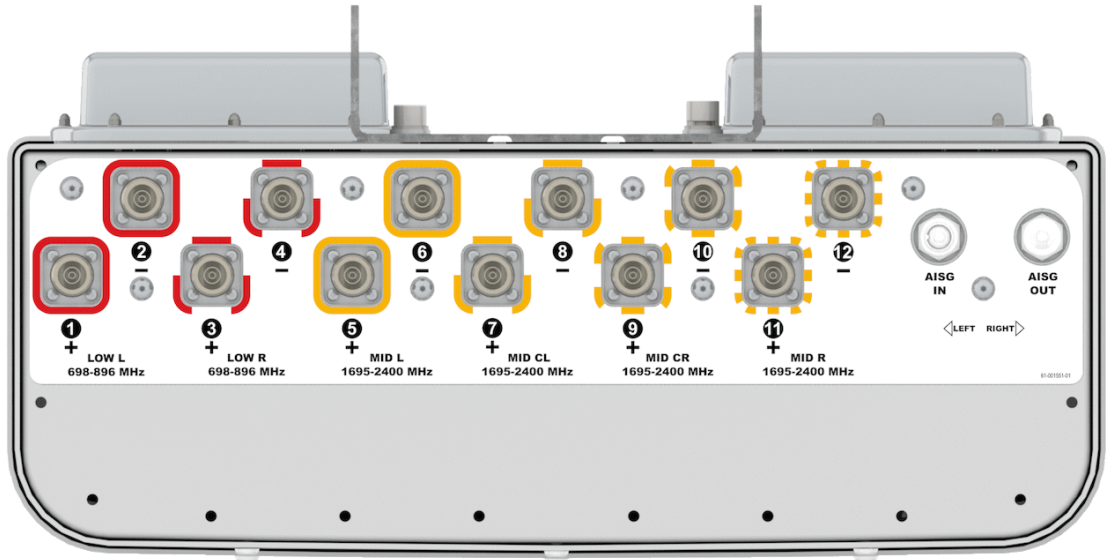

Connector Spacing

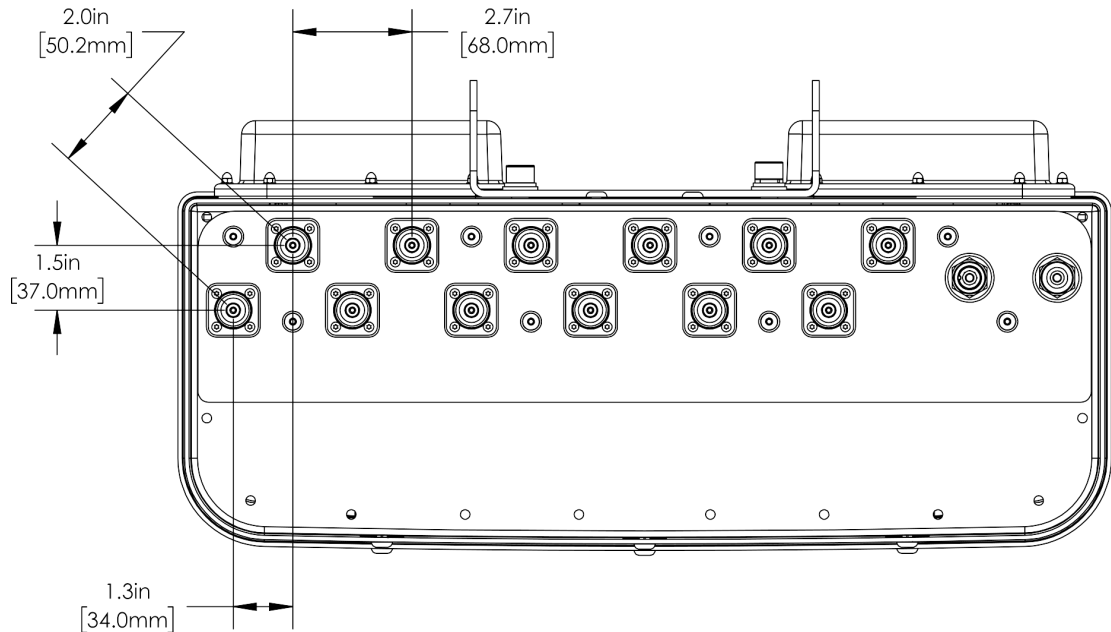

DualBand Twelve-Port Antenna

TPA65R-BU8Dv2

SPECIFICATIONS

Mechanical

RET to Element Configuration

TPA65R-BU8Dv2B Element and RET configuration (Type 17 Internal RET)

Top of antenna Viewed from rear

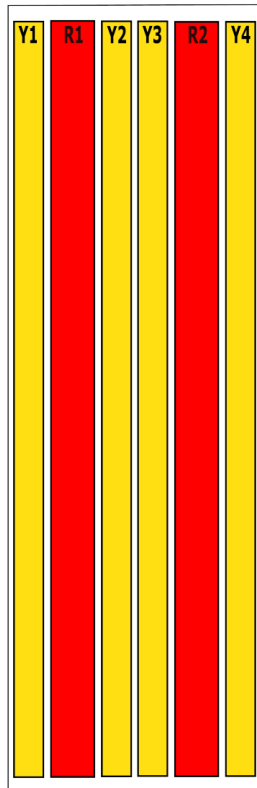

Mechanical

RET placement as viewed from rear of antenna

Top of antenna

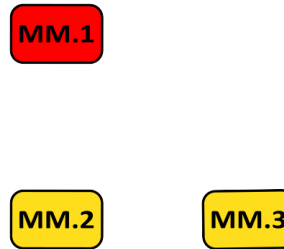

Array	Ports	Freq (MHz)	Ports controlled by common RET	AISG RET UID
R1	1, 2	698-896	1, 2, 3, 4	ClxxxxxMM.1
R2	3, 4	698-896		
Y1	5, 6	1695-2400	5, 6, 7, 8	ClxxxxxMM.2
Y2	7, 8	1695-2400		
Y3	9, 10	1695-2400		
Y4	11, 12	1695-2400	9, 10, 11, 12	ClxxxxxMM.3



SPECIFICATIONS

DualBand Twelve-Port Antenna

TPA65R-BU8Dv2

Typical Antenna Patterns

For detailed information on additional antenna patterns, contact customer support at support@cciproducts.com

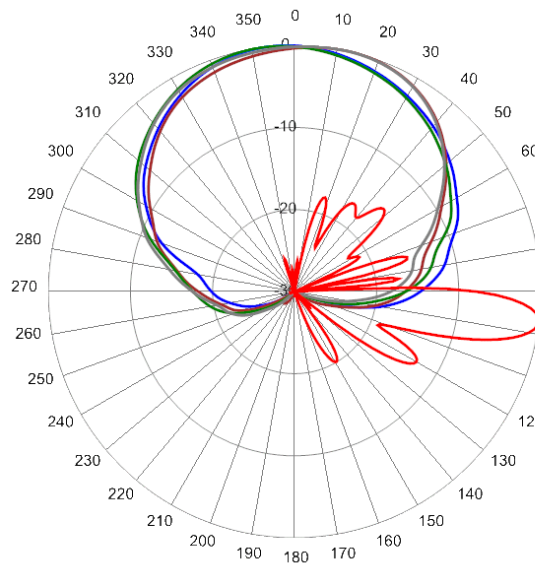

734 MHz Azimuth with Elevation 7°

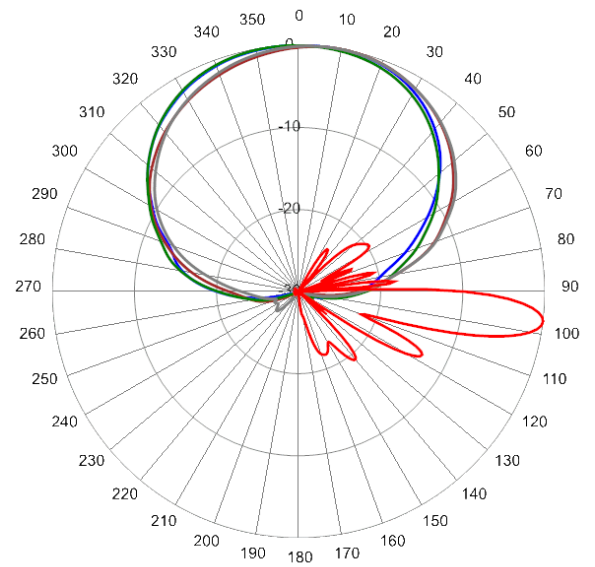

824 MHz Azimuth with Elevation 7°



DualBand Twelve-Port Antenna

TPA65R-BU8Dv2

Typical Antenna Patterns

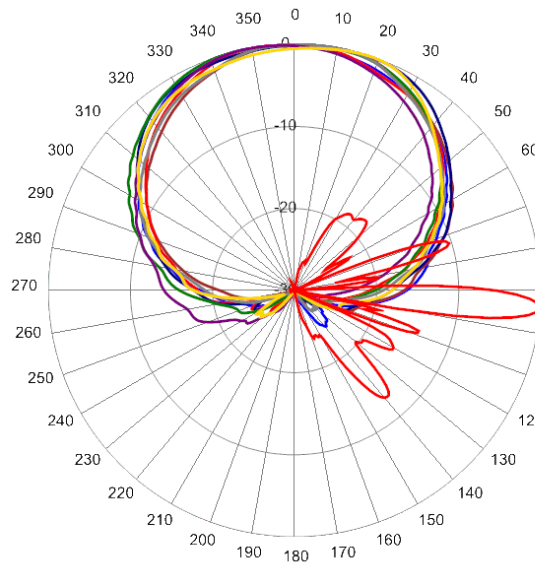

1720 MHz Azimuth with Elevation 4°

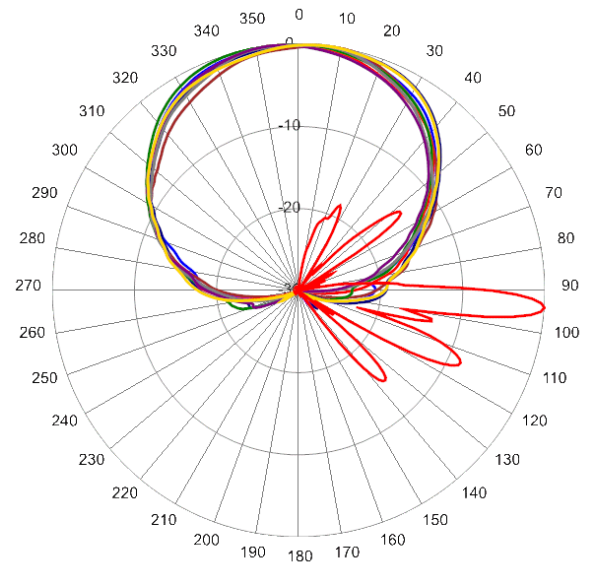

1850 MHz Azimuth with Elevation 4°

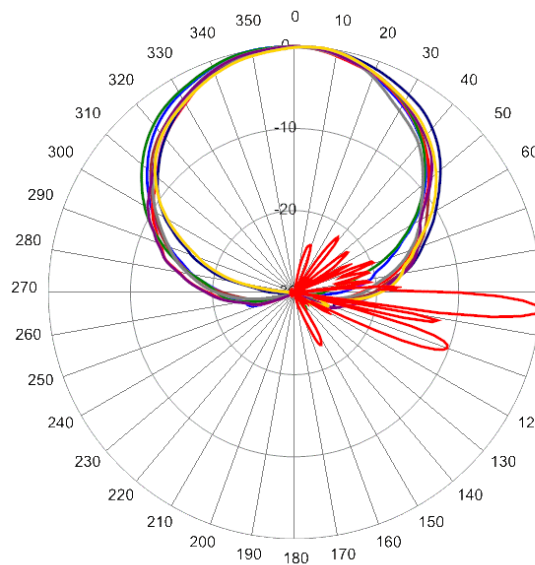

2110 MHz Azimuth with Elevation 4°

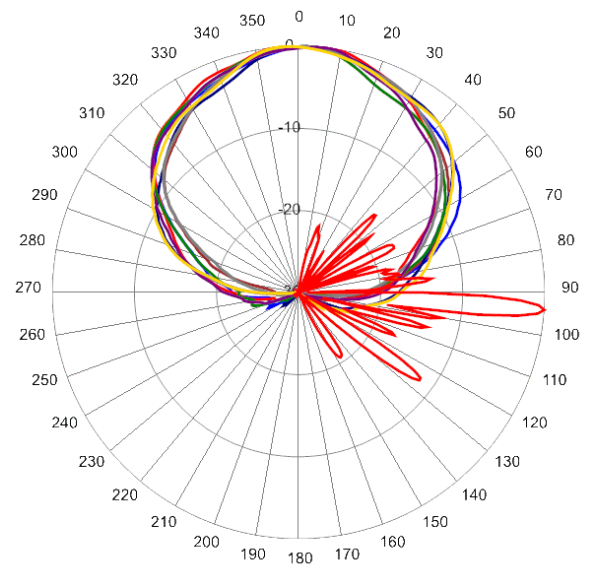

2360 MHz Azimuth with Elevation 4°



ORDERING

DualBand Twelve-Port Antenna

TPA65R-BU8Dv2

Parts & Accessories

TPA65R-BU8Dv2B-K	Eight foot (2.4 m) DualBand antenna with 65° azimuth beamwidth, 4.3-10 female connectors, 3 factory installed BSA-RET400 RET actuators and MBK-16 mounting bracket
MBK-16	Mounting bracket kit (top and bottom) with fixed 0° mechanical tilt
MBK-01	Mounting bracket kit (top and bottom) with 0° to 10° mechanical tilt adjustment
BSA-RET400	Type 17 Internal Remote Electrical Tilt System (RET)
AISGC-M-F-10FT	10 Foot (3 M) Male/Female AISG cable
SCU-AISG-P	Portable AISG 2.0 Site Control Unit



Mounting Bracket Kit

MBK-16

Mechanical

Weight	9.9 lbs (4.5 kg)
Hinge Pitch	47.25 in (1200 mm)
Mounting Pole Dimension	2 to 5 in (5 to 12 cm)
Fastener Size	M12
Installation Torque	40 ft·lbs (54 N·m)
Mechanical Tilt	0°

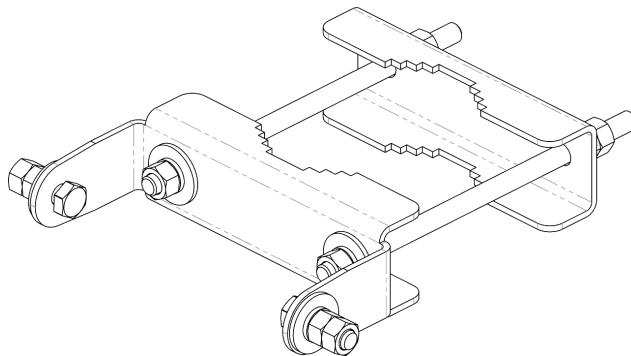
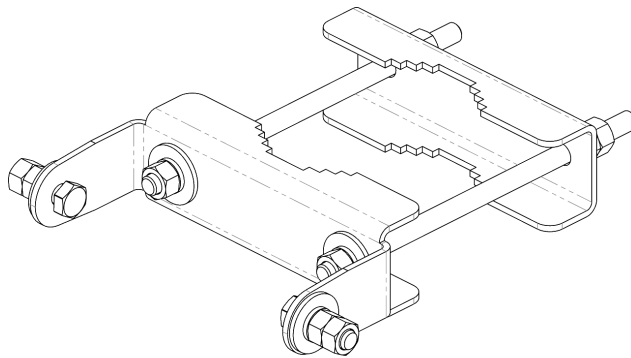

MBK-16 Top and Bottom Bracket



Mounting Bracket Kit

MBK-01

Mechanical

Weight	12.6 lbs (5.7 kg)
Hinge Pitch	47.25 in (1200 mm)
Mounting Pole Dimension	2 to 5 in (5 to 12 cm)
Fastener Size	M12
Installation Torque	40 ft·lb (54 N·m)
Mechanical Tilt Adjustment	0° - 10°

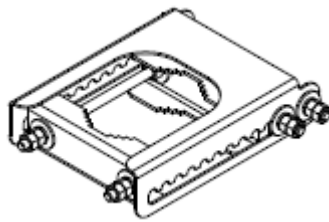

MBK-01 Top Adjustable Bracket

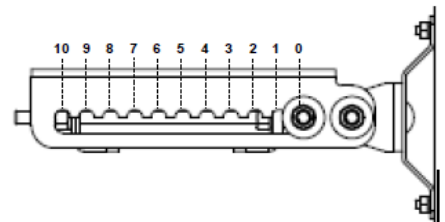

MBK-01 Top Adjustable Bracket Side View

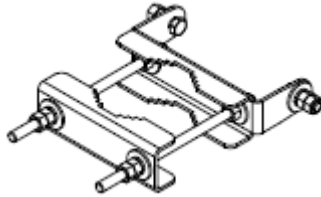

MBK-01 Bottom Fixed Bracket



Internal Remote Electrical Tilt (iRET)

BSA-RET400

General Specifications

Part Number	BSA-RET400
Protocols	AISG 2.0
RET Type	Type 17
Adjustment Cycles	>10,000 cycles
Tilt Accuracy	±0.1°
Temperature Range	-40° C to 70° C

Electrical

Data Interface Signal	DC
Input Voltage	10-30 Vdc
Current Consumption Tilt	100 mA at $V_{in}=24$ (500 mA MAX)
Current Consumption Idle	10 mA at $V_{in}=24$

Mechanical

Dimensions (LxWxD)	7.0x5.3x1.8 in. (179x134x45 mm)
Housing	ASA/ABS/Aluminum
Weight	1.3 lbs (0.6 kg)

ASA= Acrylic Styrene Acrylonitrile
ABS=Acrylonitrile Butadiene Styrene

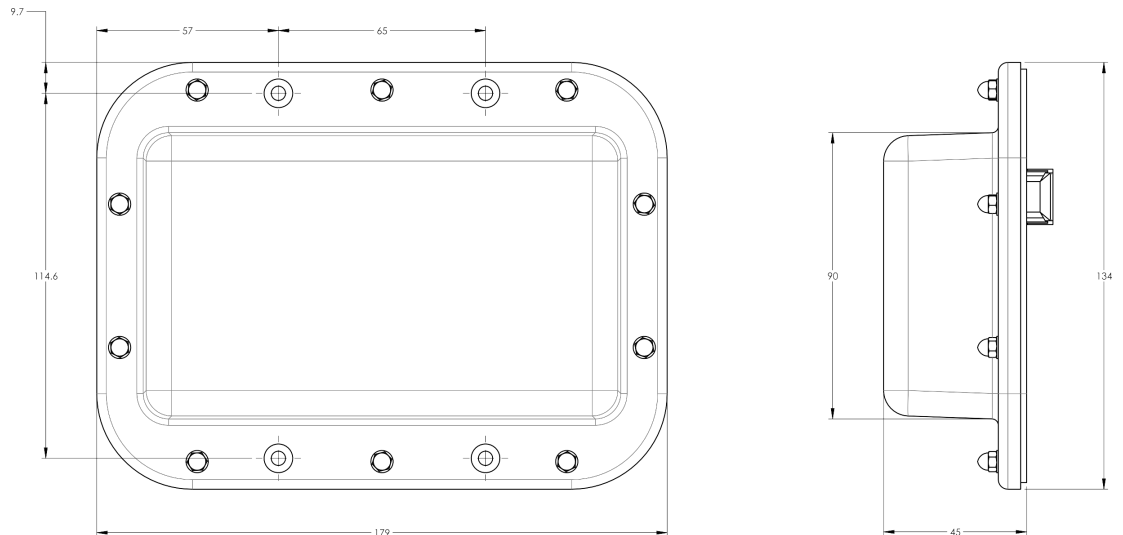



STANDARDS & CERTIFICATIONS

DualBand Twelve-Port Antenna

TPA65R-BU8Dv2

Standards & Compliance

Safety	EN 60950-1, UL 60950-1
Emission	EN 55022
Immunity	EN 55024
Environmental	IEC 60068-2-1, IEC 60068-2-2, IEC 60068-2-5, IEC 60068-2-6, IEC-60068-2-11, IEC 60068-2-14, IEC 60068-2-18, IEC 60068-2-27, IEC 60068-2-29, IEC 60068-02-30, IEC 60068-2-52, IEC 60068-2-64, GR-63-CORE 4.3.1, EN 60529, IP 24

Certifications

Antenna Interface Standards Group (AISG), Federal Communication Commission (FCC) Part 15 Class B, CE, CSA US, ISO 9001

