



Antennas

Six Beam 4 x 4 MIMO Special Events Antenna

MBM6F-E3B

DATA SHEET



- Three foot (1.0 m) tall, single band, twenty-four port Multifunction Multibeam array. Containing Six Independent LTE Optimized Beams with 4x4 MIMO capability or Twelve Independent LTE Optimized Beams with 2x2 MIMO capability covering 1695-2690 MHz frequencies, an Industry First
- Twenty-Four High Band Dual-Pol +45°/-45°ports (Two or Four ports per Beam) covering 1695-2690 MHz in a single antenna
- Full Spectrum Compliance for 1695-2690 MHz Frequencies
- Unique Antenna Configuration provides the end user with complete flexibility with both the MIMO Configuration and High Band Frequency Configuration of each beam, an Industry First
- Deployment of a 4x4 MIMO LTE Optimized Beam allows for greater capacity and data throughput over a conventional 2x2 MIMO LTE Optimized Beam deployment. Essential for today's LTE Data Driven Networks
- LTE Optimized Beams for improved LTE data throughput by minimizing beam crossover, providing for an efficient use of valuable radio capacity and frequency spectrum. Essential for today's LTE Data Driven Networks
- LTE Optimized FBR, USLS and Co-Pol Beam Isolation Performance. Essential for today's LTE Data Driven Networks
- Exceeds minimum PIM performance requirements

Overview

This CCI Multifunction Multibeam Antenna contains Six Independent LTE Optimized Beams with 4x4 MIMO capability or Twelve Independent LTE Optimized Beams with 2x2 MIMO capability. This Multifunction Multibeam Antenna is intended for use at data hotspots and other congested locals, where social media and the ability to share photos and videos and other high demand applications require high capacity and high data rates.

This Multifunction Multibeam Antenna enables maximum spectrum re-use by sectorization, greatly increasing network capacity. With deployment of 4x4 MIMO (on any of the beams available), capacity and data throughput is greatly enhanced, over a conventional 2x2 MIMO beam deployment. Our LTE Optimized Beam Design approach provides fast roll off between beams, minimizing interference between sectors thus increasing the carrier to interference plus noise (CINR) ratio and lowering soft handover losses in LTE networks. Such an approach enhances data transfer rates within LTE network sectors and addresses "hotspots" in mobile wireless operator networks.

The single panel design of the CCI Multifunction Multibeam Special Event Antenna offers the opportunity to reduce antenna count and directly replaces multiple narrow beam antennas. The antenna minimizes the need for optimization as each beam is spaced optimally for maximum throughput thus providing significant CAPEX and OPEX cost savings.

CCI antennas are designed and produced to ISO 9001 certification standards for reliability and quality in our state-of-the-art manufacturing facilities.

Applications

- Upgrade of data-throughput and capacity, through the use of 4x4 MIMO deployment
- Antenna intended for use where data throughput and capacity needs are paramount



Antennas

SIX BEAM 4 x 4 MIMO SPECIAL EVENTS ANTENNA SPECIFICATIONS

MBM6F-E3B

Electrical

Ports	24 x High Band Ports for 1695-2690 MHz				
Frequency Range	1695-1880 MHz	1850-1995 MHz	1920-2180 MHz	2300-2400 MHz	2496-2690 MHz
Gain (Peak)	21.1 dBi	21.4 dBi	22.1 dBi	22.7 dBi	23.5 dBi
Azimuth Beamwidth (-3dB)	11.2°	10.0°	9.4°	7.9°	6.9°
Azimuth Beam Crossover	10.0 dB	10.0 dB	10.0 dB	10.0 dB	10.0 dB
Elevation Beamwidth (-3dB)	17.9°	16.0°	15.4°	13.1°	11.5°
Electrical Downtilt	7°	7°	7°	7°	7°
Elevation Sidelobes (1st Upper) (Typ.)	< -22 dB	< -19 dB	< -18 dB	< -16 dB	< -20 dB
Front-to-Back Ratio @180° (Typ.)	> 35 dB	> 35 dB	> 35 dB	> 35 dB	> 35 dB
Cross-Polar Discrimination (at Peak)	> 24 dB	> 23 dB	> 23 dB	> 22 dB	> 20 dB
Cross-Polar Port-to-Port Isolation	> 25 dB	> 25 dB	> 25 dB	> 25 dB	> 25 dB
Interbeam Co-Pol Isolation	> 15 dB	> 15 dB	> 15 dB	> 15 dB	> 15 dB
Interbeam Co-Pol isolation (Non-Adjacent Beams) (Worse Case)	> 12 dB	> 12 dB	> 12 dB	> 12 dB	> 12 dB
Voltage Standing Wave Ratio(VSWR)	< 1.5:1	< 1.5:1	< 1.5:1	< 1.5:1	< 1.5:1
Passive Intermodulation (2x20W)	≤ -153 dBc	≤ -153 dBc	≤ -153 dBc	≤ -153 dBc	≤ -153 dBc
Input Power Continuous Wave (CW)	200 watts	200 watts	200 watts	200 watts	200 watts
Polarization	Dual Pol 45°	Dual Pol 45°	Dual Pol 45°	Dual Pol 45°	Dual Pol 45°
Input Impedance	50 ohms	50 ohms	50 ohms	50 ohms	50 ohms
Lightning Protection	DC Ground	DC Ground	DC Ground	DC Ground	DC Ground

BASTA Electrical Specifications					
Frequency Range	1695-1880 MHz	1850-1995 MHz	1920-2180 MHz	2300-2400 MHz	2496-2690 MHz
Gain over all Tilts (dBi)	19.7	20.6	21.0	21.9	22.9
Gain over all Tilts Tolerance (Worse Case) (dB)	1.1	0.8	0.9	0.5	0.4
Azimuth Beamwidth Tolerance at 3 dB (°)	2.4	1.6	1.6	0.9	0.7
Elevation Beamwidth Tolerance at 3 dB (°)	1.3	1.1	0.6	0.5	0.8
Azimuth Beam Peak Tolerance (Worse Case) (°)	1.3	0.9	1.3	0.6	0.8
First Upper Sidelobes Suppression (dB)	19.9	17.7	15.5	12.5	13.6
Front-to-Back Ratio over ±20° (dB)	31.0	32.5	32.2	30.9	31.2

* Electrical specifications follow document "Recommendation on Base Station Antenna Standards" (BASTA) V12.0. All specifications are subject to change without notice.

Mechanical

Dimensions (LxWxD)	40.0x43.5x7.0 in (1017x1104x177 mm)
Survival Wind Speed	> 150 mph (> 241 kph)
Front Wind Load	371 lbs (1652 N) @ 100 mph (161 kph)
Side Wind Load	67 lbs (296 N) @ 100 mph (161 kph)
Equivalent Flat Plate Area	14.5 ft ² (1.3 m ²)
Weight *	88.0 lbs (39.9 kg)
Connector	24x 4.3-10 female
Package Dimensions (LxWxD)	53.9x46.5x16.1 in (1370x1180x410 mm)
Package Weight	146.6 lbs (66.5 kg)
Mounting Pole	2 to 5 in (5 to 12 cm)
Mounting Pole Spacing	31.5 in (800 mm)

* Weight excludes mounting



Antennas

SIX BEAM 4 x 4 MIMO SPECIAL EVENTS ANTENNA SPECIFICATIONS

MBM6F-E3B

Mechanical

Bottom View

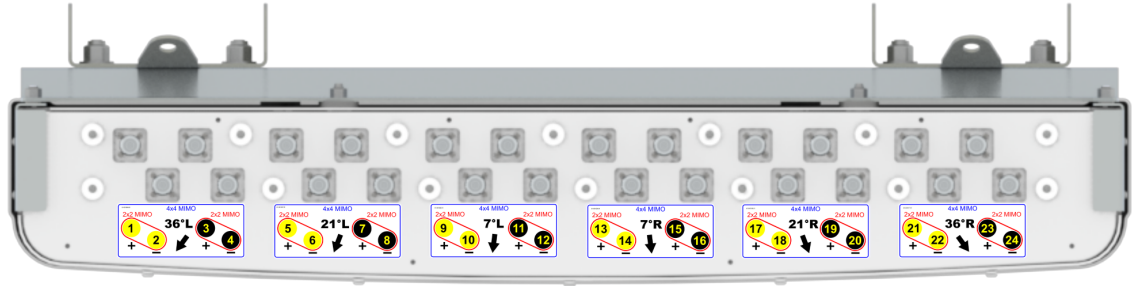

Connector Spacing

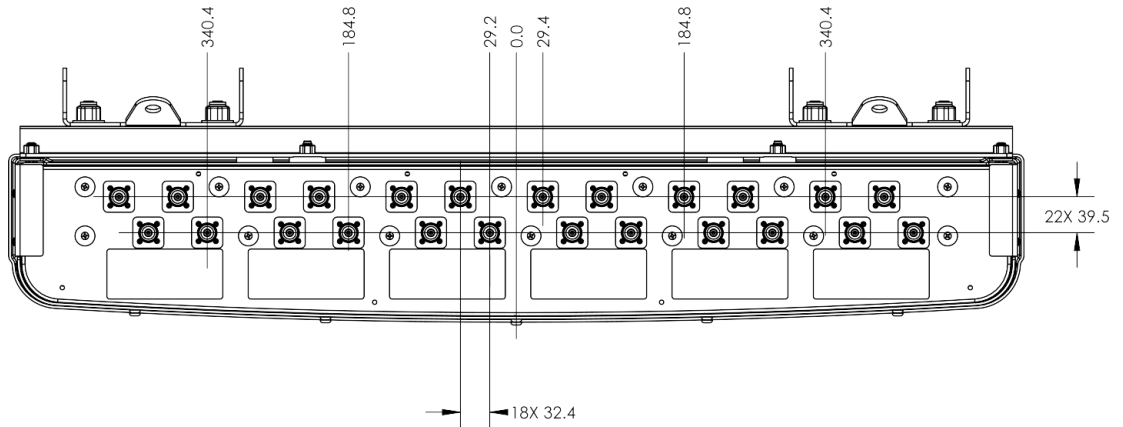

Radio Connects Options

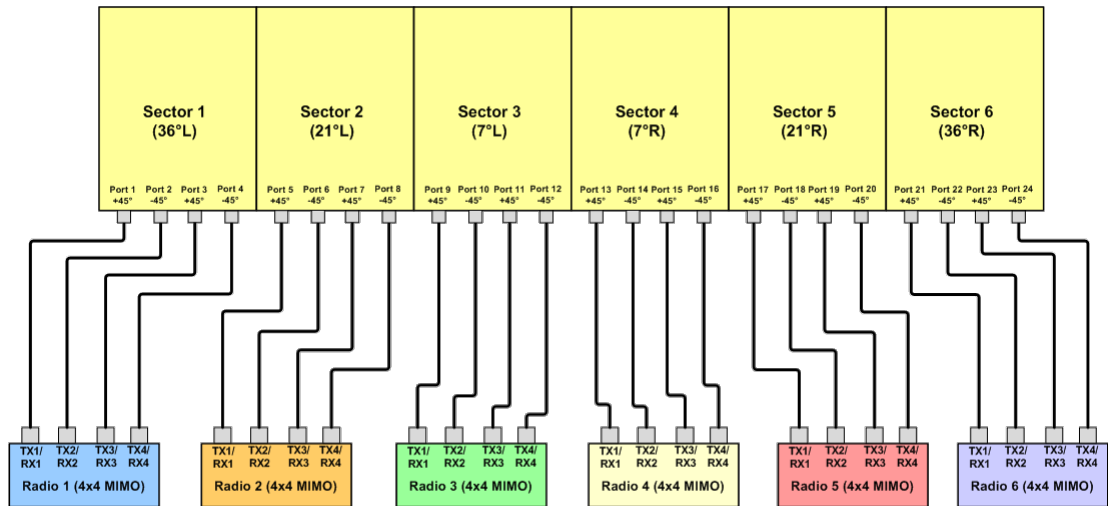

MBM Series "E Band" Multisector Antenna (4x4 Connection)



Antennas

Six Beam 4 x 4 MIMO Special Events Antenna SPECIFICATIONS

MBM6F-E3B

Mechanical

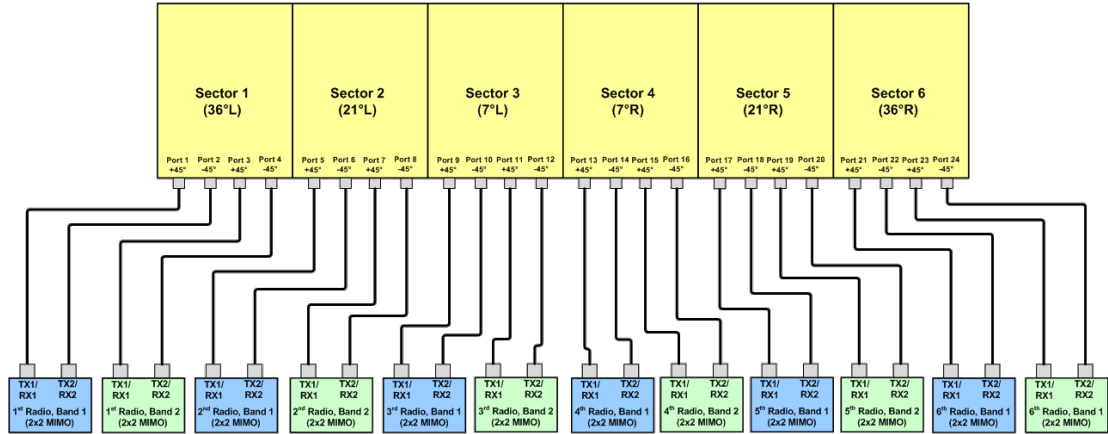

MBM Series "E Band" Multisector Antenna (2x2_Two Band Connection)

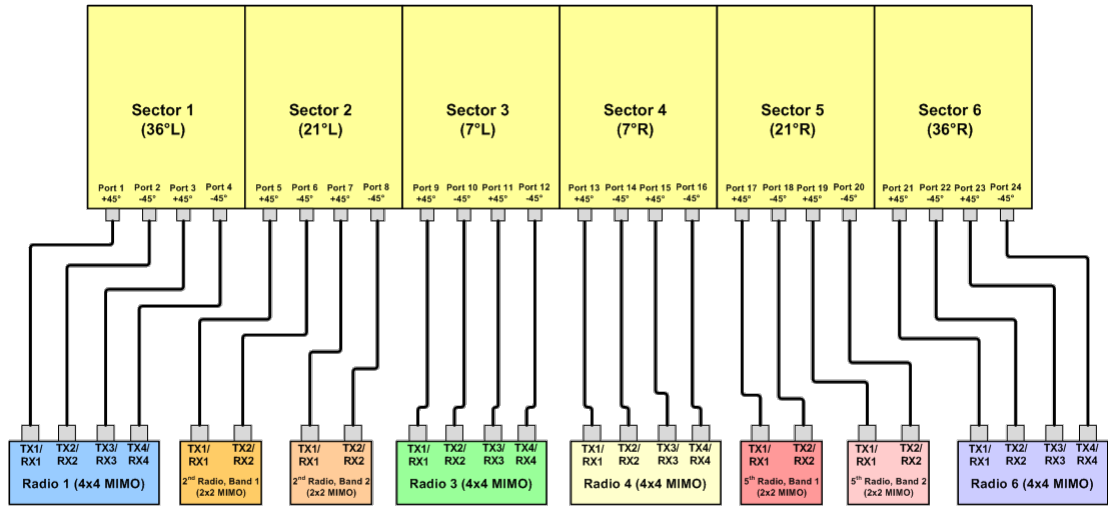

MBM Series "E Band" Multisector Antenna (4x4_and_2x2 Mixed Connection)



Antennas

SIX BEAM 4 x 4 MIMO SPECIAL EVENTS ANTENNA SPECIFICATIONS

MBM6F-E3B

Typical Antenna Patterns

For detailed information on additional antenna patterns, contact customer support at support@cciproducts.com

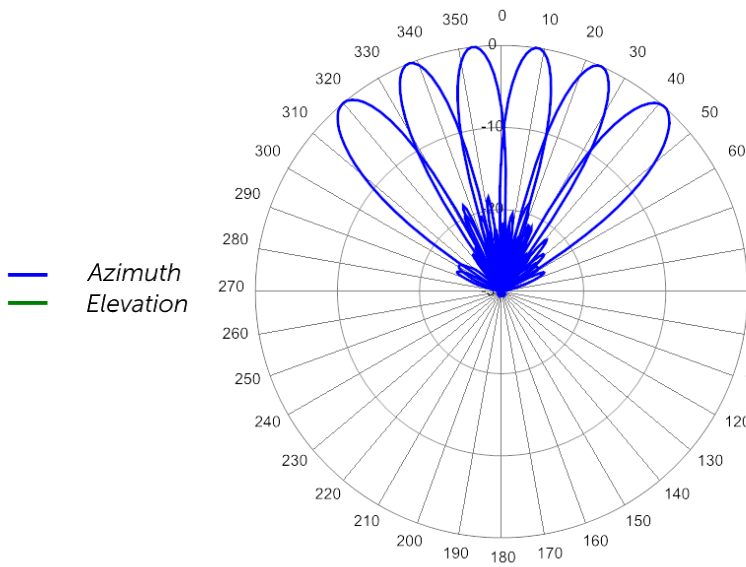

1930 MHz Azimuths

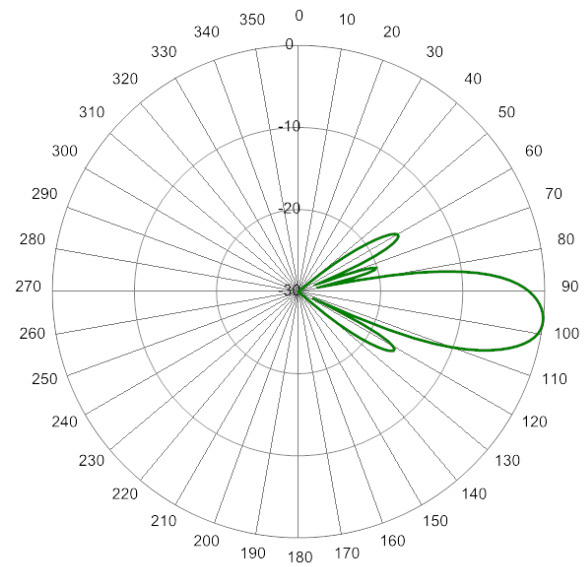

1930 MHz Elevation 7°

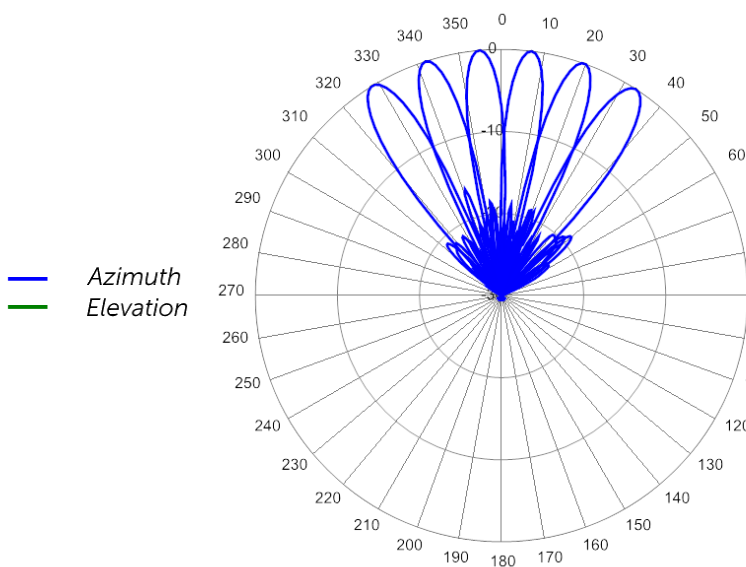

2360 MHz Azimuths

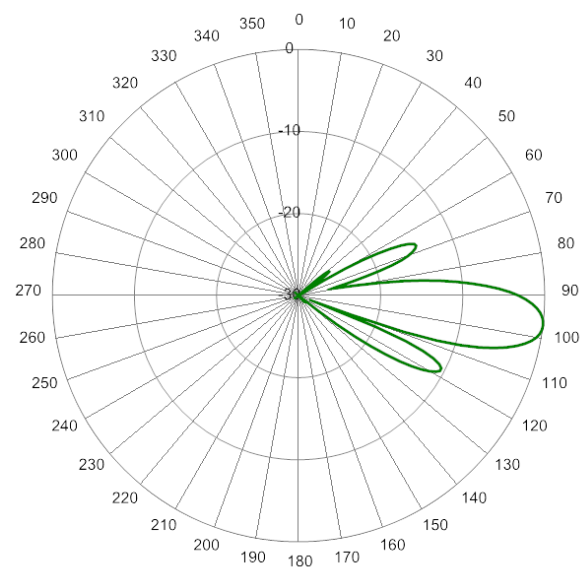

2360 MHz Elevation 7°



Antennas

SPECIFICATIONS Six Beam 4 x 4 MIMO Special Events Antenna

MBM6F-E3B

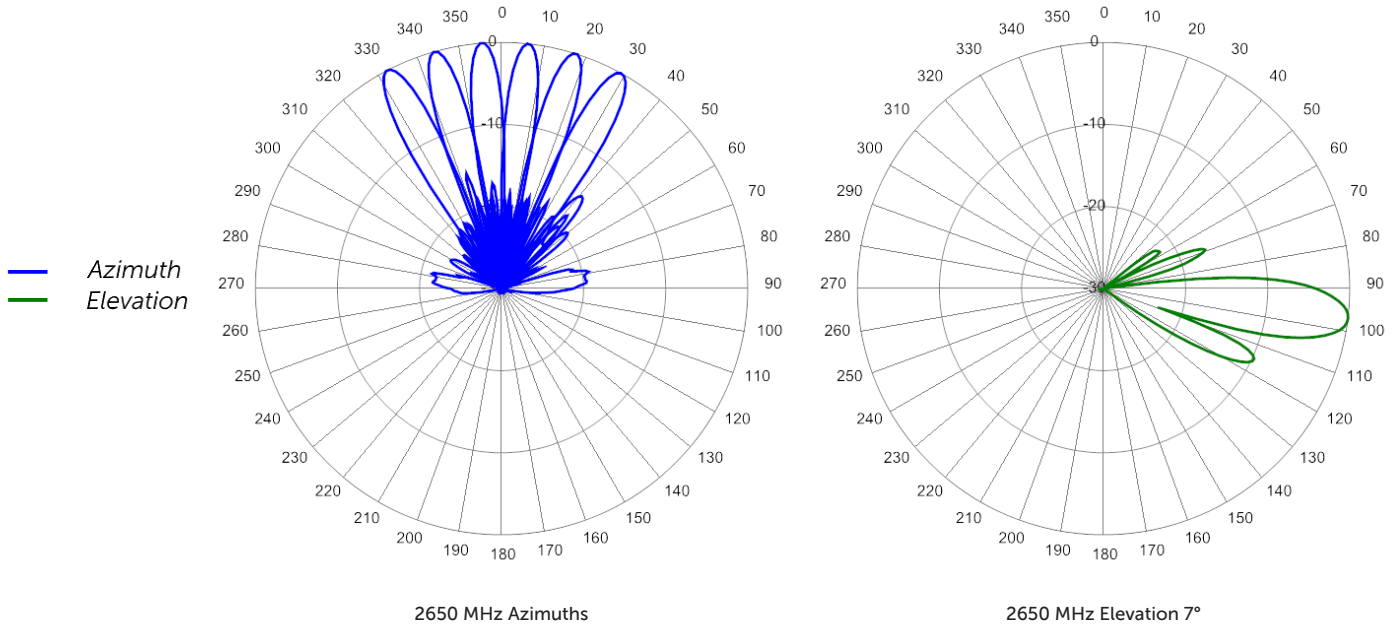



Antennas

ORDERING Six Beam 4 x 4 MIMO Special Events Antenna

MBM6F-E3B

Parts & Accessories

MBM6F-E3BA-K 3 foot (1.0 m) Special Events 6-Beam MIMO Antenna with fixed electrical tilt, 4.3-10 connectors and MBK-10 mounting brackets.

MBK-10 Mounting bracket kit (top and bottom) with 0° to 10° mechanical tilt adjustment (x2)



Antennas

ACCESSORIES

Mounting Bracket Kit

MBK-10

Mechanical

Weight	14.0 lbs (6.4 kg)
Hinge Pitch	23.6 in (600 mm)
Mounting Pole Dimension	2 to 5 in (5 to 12 cm)
Fastener Size	M12
Installation Torque	40 ft·lb (54 N·m)
Mechanical Tilt Adjustment	0° - 10°

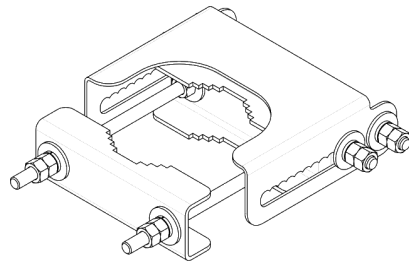

MBK-10 Top Adjustable Bracket

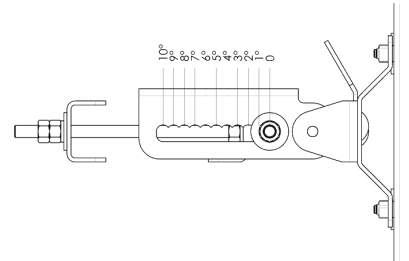

MBK-10 Top Adjustable Bracket Side View

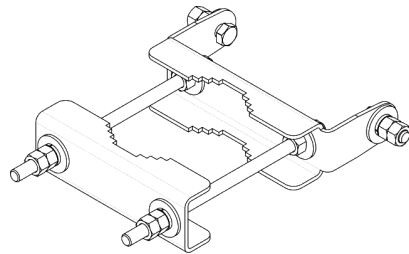

MBK-10 Bottom Fixed Bracket



Antennas

STANDARDS & CERTIFICATIONS

Six Beam 4 x 4 MIMO Special Events Antenna

MBM6F-E3B

Standards & Compliance

Environmental IEC 60068-2-1, IEC 60068-2-2, IEC 60068-2-5,
 IEC 60068-2-6, IEC-60068-2-11, IEC 60068-2-14,
 IEC 60068-2-18, IEC 60068-2-27, IEC 60068-2-29,
 IEC 60068-02-30, IEC 60068-2-52, IEC 60068-2-64,
 GR-63-CORE 4.3.1, EN 60529, IP 24

Certifications

Federal Communication Commission (FCC) Part 15 Class B, ISO 9001



CCI

Communication Components Inc.

EXTENDING WIRELESS PERFORMANCE