



# Antennas

DATA SHEET

## Hybrid Bi-Sector™ Array

HBSA33R-KE4A



- Four foot (1.2 m), multiband, six port Hybrid Bi-Sector™ Antenna. Deploying a high performing 65° azimuth beamwidth covering 698-960 MHz and a pair of CCI's Patented Asymmetrical 33° Shaped Beams covering 1695-2690 MHz frequencies
- Four wide high band ports covering 1695-2690 MHz and two wide low band ports covering 698-960 MHz in a single antenna
- Narrow Enclosure, 13.7" (348mm) width. Narrowest Enclosure in the Industry for this type of Antenna
- Full Spectrum Compliance for 698-960 MHz / 1695-2690
- LTE Optimized Asymmetric Shaped Beams for improved LTE data throughput by minimizing beam crossover, providing for an efficient use of valuable radio capacity and frequency spectrum
- LTE Optimized FBR, SPR and Boresight/Sector XPD Performance. Essential for today's LTE Data Networks
- Exceeds minimum PIM performance requirements
- Equipped with new 4.3-10 connector, which is 40% smaller than traditional 7/16 DIN connector
- Equipped with Three Field Replaceable, integrated AISG 2.0 compliant Remote Electrical Tilt (RET)

### Overview

This CCI Hybrid Bi-Sector™ Multiband Array is a six port antenna, which is designed to provide maximum deployment flexibility. With four wide high band ports (two ports per beam) covering 1695-2690 MHz across two 33° asymmetrically shaped beams and two wide low band ports covering 698-960 MHz across a 65° HBW.

The antenna implements CCI's proven "Asymmetrical Beam for Spectrum Efficiency" patent which enables wireless operators to re-use their valuable spectrum and significantly increase capacity. The CCI Hybrid Bi-Sector™ Array provides two 33° asymmetrically shaped beams designed to maximize coverage while minimizing interference and overlap in dense LTE environments.

With this configuration, the antenna is capable of providing 2x2 Multiple-input Multiple-output (MIMO) across the 65° Low Band ports and Dual 2x2 Multiple-input Multiple-output (MIMO) across the two 33° asymmetrically shaped beams.

CCI's Hybrid Bi-Sector™ Array antennas allow operators to reduce antenna and site deployments, for either six sector or greenfield deployments, by replacing traditional 65° antennas with CCI's Patented Bi-Sector™ Array antennas containing two 33° Asymmetric Beams. This is achieved through a single panel array producing significant CAPEX and OPEX cost savings for the operator, while increasing cell site capacity and LTE data throughput.

CCI antennas are designed and produced to ISO 9001 certification standards for reliability and quality in our state-of-the-art manufacturing facilities.



# Antennas

DATA SHEET

Hybrid Bi-Sector™ Array

HBSA33R-KE4A

## Applications

- Dual 2x2 MIMO on High Band and 2x2 MIMO on Low Band
- Ready for Network Standardization on 4.3-10 connectors
- Ideal Antenna Solution for structurally constrained sites, where data throughput, capacity and limited spectrum is a concern
- With CCI's Hybrid Bi-Sector™ Antenna, wireless operators can connect multiple platforms to a single antenna, reducing tower load, lease expense, deployment time and installation cost



# Antennas

## Hybrid Bi-Sector™ Array

HBSA33R-KE4A

### SPECIFICATIONS

#### Electrical

Ports	2 × Low Band Ports for 698-960 MHz			
Frequency Range	698-806 MHz	790-862 MHz	824-896 MHz	880-960 MHz
Gain <sup>1</sup>	13.0 dBi	13.1 dBi	13.2 dBi	13.3 dBi
Gain (Average) <sup>2</sup>	12.7 dBi	12.7 dBi	12.9 dBi	13.0 dBi
Azimuth Beamwidth (-3dB)	68°	74°	71°	66°
Elevation Beamwidth (-3dB)	19.7°	17.7°	17.0°	16.0°
Electrical Downtilt	0° to 14°	0° to 14°	0° to 14°	0° to 14°
Elevation Sidelobes (1st Upper)	< -19 dB	< -19 dB	< -19 dB	< -18 dB
Front-to-Back Ratio @180°	> 30 dB	> 35 dB	> 35 dB	> 35 dB
Front-to-Back Ratio over ± 20°	> 30 dB	> 32 dB	> 32 dB	> 32 dB
Cross-Polar Discrimination (at Peak)	> 23 dB	> 25 dB	> 25 dB	> 24 dB
Cross-Polar Discrimination (at 3 dB) <sup>2</sup>	20.4 dB	20.1 dB	18.5 dB	17.0 dB
Cross-Polar Port-to-Port Isolation	> 25 dB	> 25 dB	> 25 dB	> 25 dB
Voltage Standing Wave Ratio (VSWR)	< 1.5:1	< 1.5:1	< 1.5:1	< 1.5:1
Passive Intermodulation (2x20W)	≤ -153 dBc	≤ -153 dBc	≤ -153 dBc	≤ -153 dBc
Input Power Continuous Wave (CW)	500 watts	500 watts	500 watts	300 watts
Polarization	Dual Pol 45°	Dual Pol 45°	Dual Pol 45°	Dual Pol 45°
Input Impedance	50 ohms	50 ohms	50 ohms	50 ohms
Lightning Protection	DC Ground	DC Ground	DC Ground	DC Ground

<sup>1</sup>Peak gain across sub-bands.

<sup>2</sup>Electrical specifications follow document "Recommendation on Base Station Antenna Standards" (BASTA) V9.6.

Ports	4 × High Band Ports for 1695-2690 MHz				
Frequency Range	1695-1880 MHz	1850-1990 MHz	1920-2180 MHz	2300-2400 MHz	2496-2690 MHz
Gain <sup>1</sup>	18.2 dBi	17.7 dBi	19.0 dBi	19.2 dBi	19.5 dBi
Gain (Average) <sup>2</sup>	17.3 dBi	18.1 dBi	18.4 dBi	18.6 dBi	18.9 dBi
Azimuth Beamwidth (-3dB)	36°	33°	31°	29°	27°
Elevation Beamwidth (-3dB)	8.0°	7.2°	6.7°	6.0°	5.7°
Electrical Downtilt	0° to 10°	0° to 10°	0° to 10°	0° to 10°	0° to 10°
Elevation Sidelobes (1st Upper)	< -18 dB	< -17 dB	< -17 dB	< -17 dB	< -18 dB
Front-to-Back Ratio @180°	> 35 dB	> 35 dB	> 35 dB	> 35 dB	> 35 dB
Front-to-Back Ratio over ± 20°	> 32 dB	> 33 dB	> 35 dB	> 34 dB	> 34 dB
Cross-Polar Discrimination (at Peak)	> 25 dB	> 25 dB	> 25 dB	> 25 dB	> 25 dB
Cross-Polar Discrimination (at 3 dB) <sup>2</sup>	18.8 dB	18.1 dB	16.3 dB	13.1 dB	15.7 dB
Cross-Polar Port-to-Port Isolation	> 25 dB	> 25 dB	> 25 dB	> 25 dB	> 25 dB
Voltage Standing Wave Ratio(VSWR)	< 1.5:1	< 1.5:1	< 1.5:1	< 1.5:1	< 1.5:1
Passive Intermodulation (2x20W)	≤ -153 dBc	≤ -153 dBc	≤ -153 dBc	≤ -153 dBc	≤ -153 dBc
Input Power Continuous Wave (CW)	300 watts	300 watts	300 watts	300 watts	300 watts
Polarization	Dual Pol 45°	Dual Pol 45°	Dual Pol 45°	Dual Pol 45°	Dual Pol 45°
Input Impedance	50 ohms	50 ohms	50 ohms	50 ohms	50 ohms
Lightning Protection	DC Ground	DC Ground	DC Ground	DC Ground	DC Ground

<sup>1</sup>Peak gain across sub-bands.

<sup>2</sup>Electrical specifications follow document "Recommendation on Base Station Antenna Standards" (BASTA) V9.6.



# Antennas

## SPECIFICATIONS

### Hybrid Bi-Sector™ Array

HBSA33R-KE4A

#### Mechanical

<b>Dimensions (LxWxD)</b>	48.3x13.7x8.5 in (1227x348x216 mm)
<b>Survival Wind Speed</b>	> 150 mph (> 241 kph)
<b>Front Wind Load</b>	147 lbs (652 N) @ 100 mph (161 kph)
<b>Side Wind Load</b>	98 lbs (435 N) @ 100 mph (161 kph)
<b>Equivalent Flat Plate Area</b>	5.7 ft <sup>2</sup> (0.5 m <sup>2</sup> )
<b>Weight<sup>1</sup></b>	35.2 lbs (16.0 kg)
<b>RET System Weight</b>	5.0 lbs (2.3 kg)
<b>Connector</b>	6 x4.3-10 female
<b>Mounting Pole</b>	2 to 5 in (5 to 12 cm)

<sup>1</sup> Weight excludes mounting kit and RET



# Antennas

## SPECIFICATIONS

### Hybrid Bi-Sector™ Array

HBSA33R-KE4A

#### Mechanical

Bottom View

HBSA33R-KE4AA

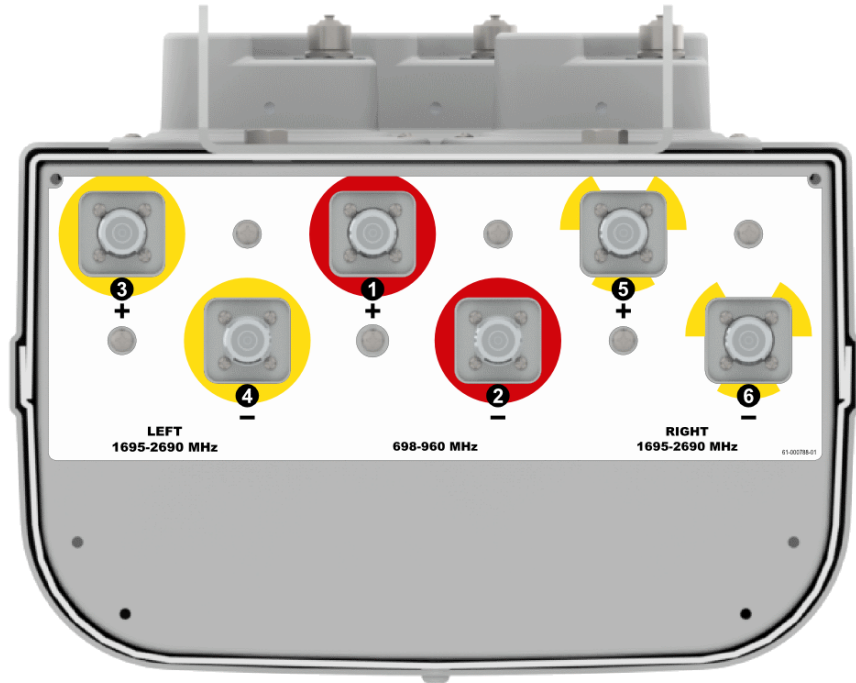

#### Connector Spacing

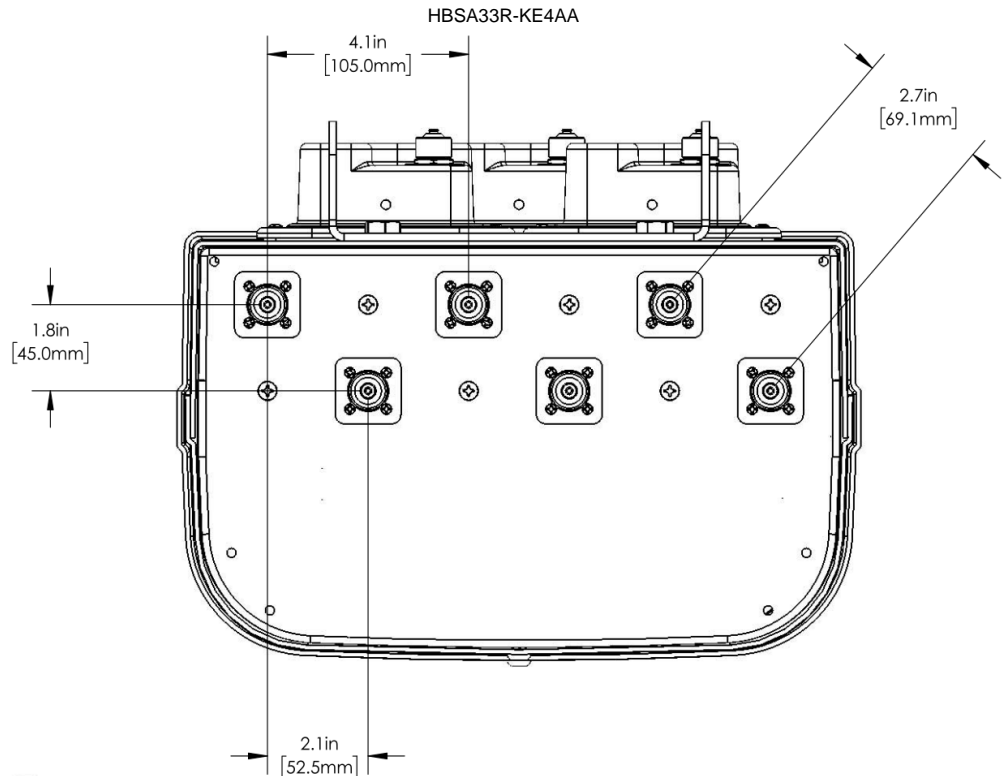



# Antennas

SPECIFICATIONS

Hybrid Bi-Sector™ Array

HBSA33R-KE4A

Mechanical

RET to Element Configuration

HBSA33R-KE4AA

## Element arrays as viewed from rear of antenna

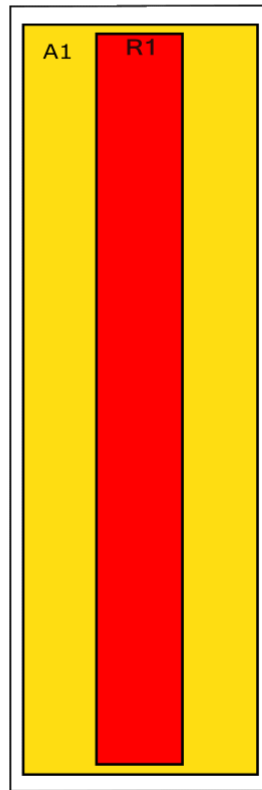

## RET placement as viewed from rear of antenna

### Top of antenna

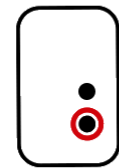

698-960  
Ports 1 & 2  
(R1)

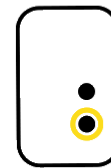

Left  
1695-2690  
Ports 3 & 4  
(A1)

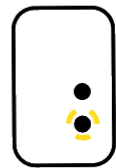

Right  
1695-2690  
Ports 5 & 6  
(A1)

Array	Ports	Freq (MHz)	Ports controlled by common RET
R1	1, 2	698-960	1, 2
A1	3, 4	1695-2690	3, 4
A1	5, 6	1695-2690	5, 6



# Antennas

## SPECIFICATIONS

### Hybrid Bi-Sector™ Array

HBSA33R-KE4A

#### Typical Antenna Patterns

For detailed information on additional antenna patterns, contact customer support at [support@cciproducts.com](mailto:support@cciproducts.com)

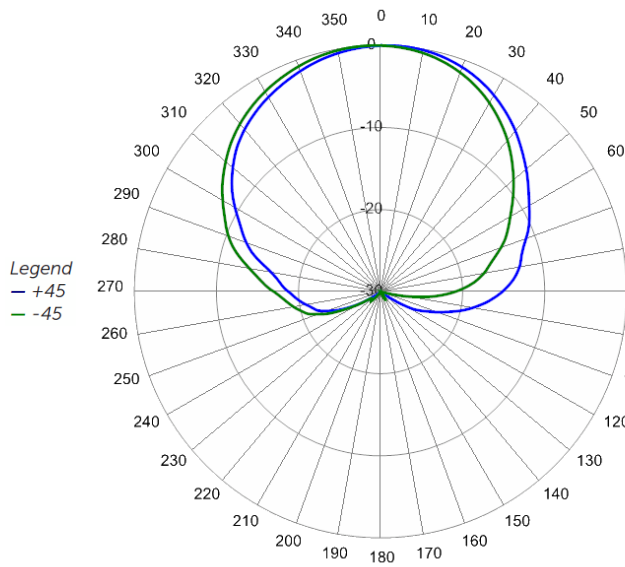

740 MHz Azimuth

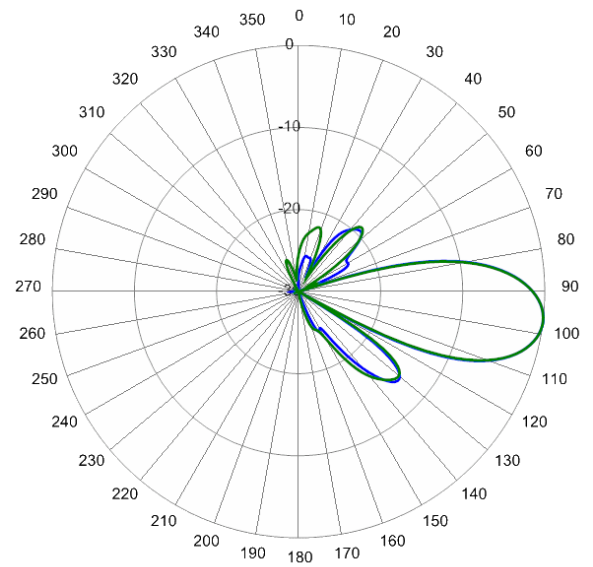

740 MHz Elevation 7°

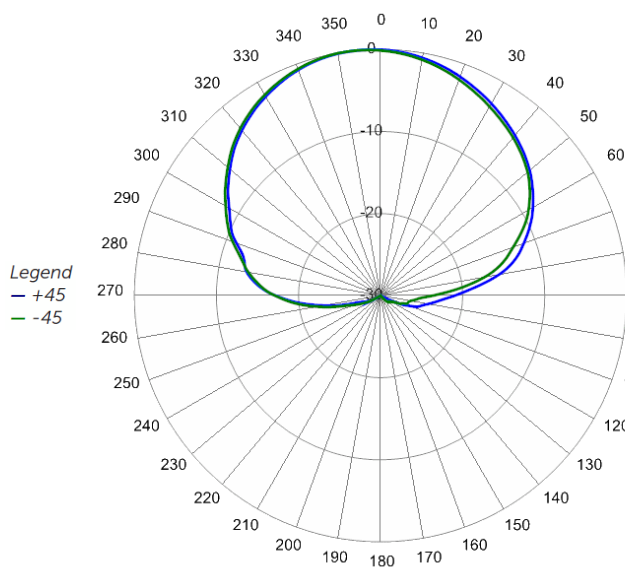

894 MHz Azimuth

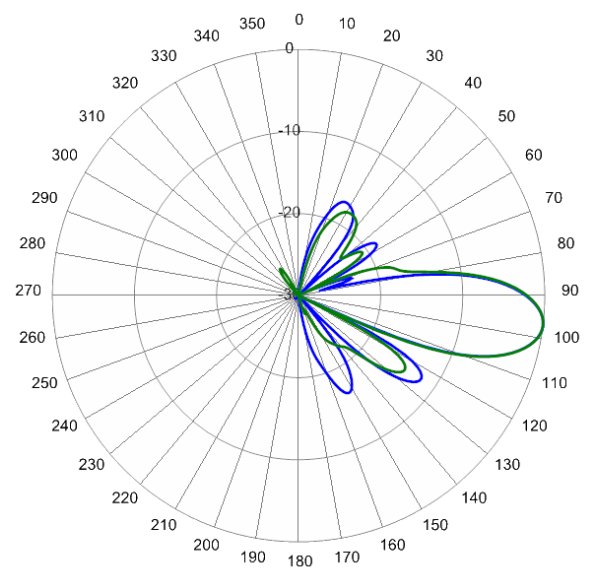

894 MHz Elevation 7°



# Antennas

SPECIFICATIONS

Hybrid Bi-Sector™ Array

HBSA33R-KE4A

Typical Antenna Patterns

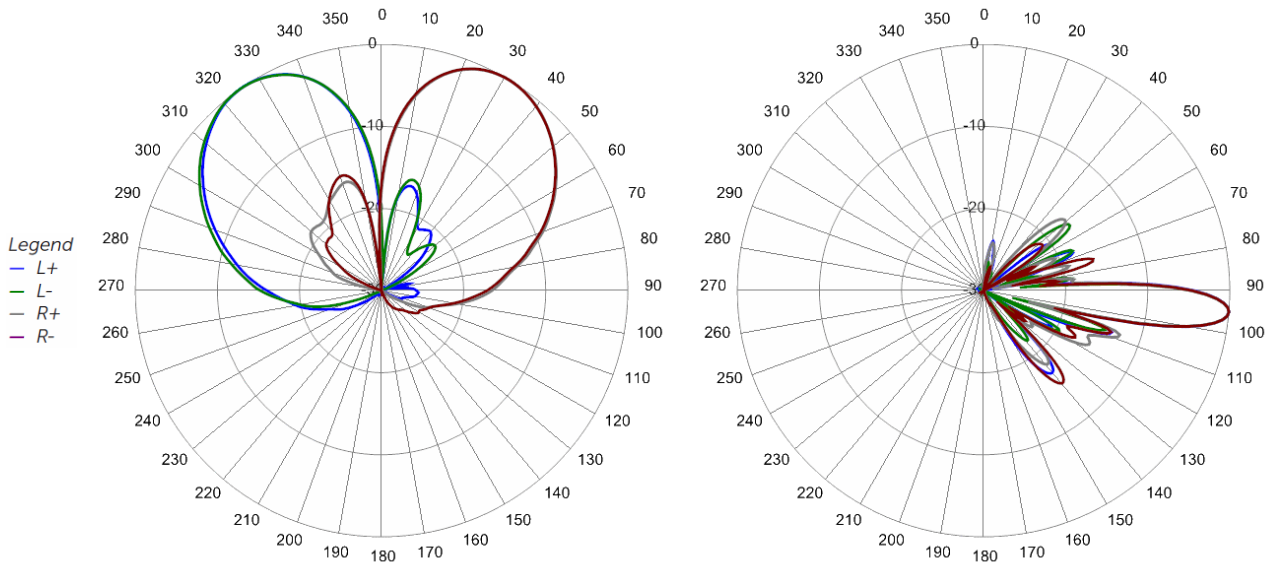

1755 MHz Azimuth Bi-Sector Ports

1755 MHz Elevation 5° Bi-Sector Ports

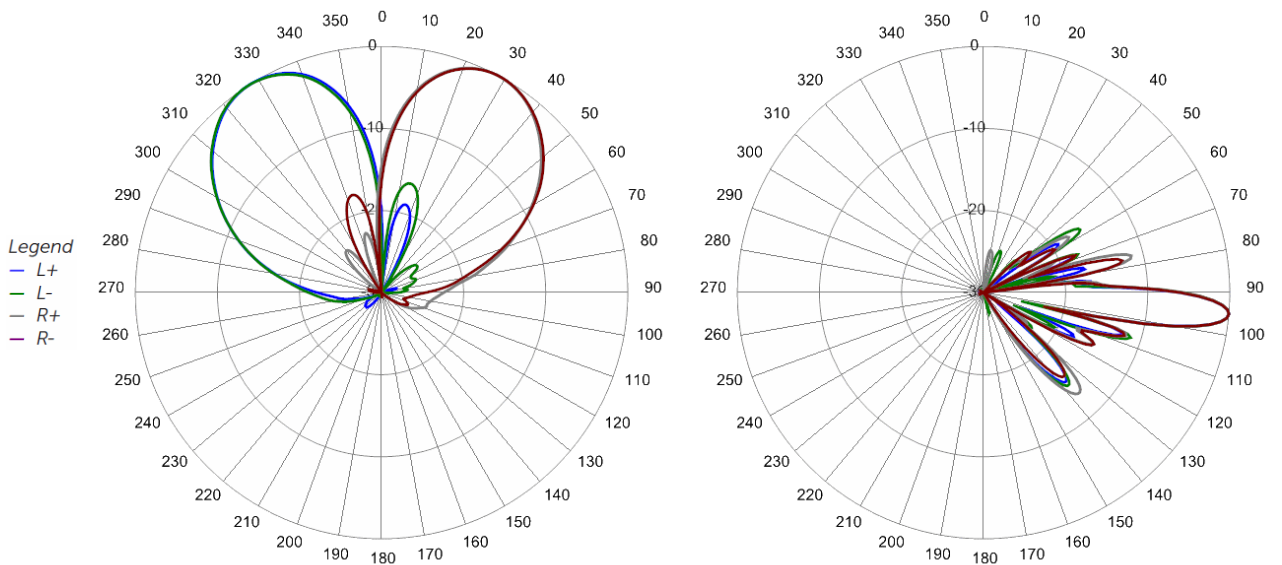

1930 MHz Azimuth Bi-Sector Ports

1930 MHz Elevation 5° Bi-Sector Ports



# Antennas

## SPECIFICATIONS

### Hybrid Bi-Sector™ Array

HBSA33R-KE4A

#### Typical Antenna Patterns

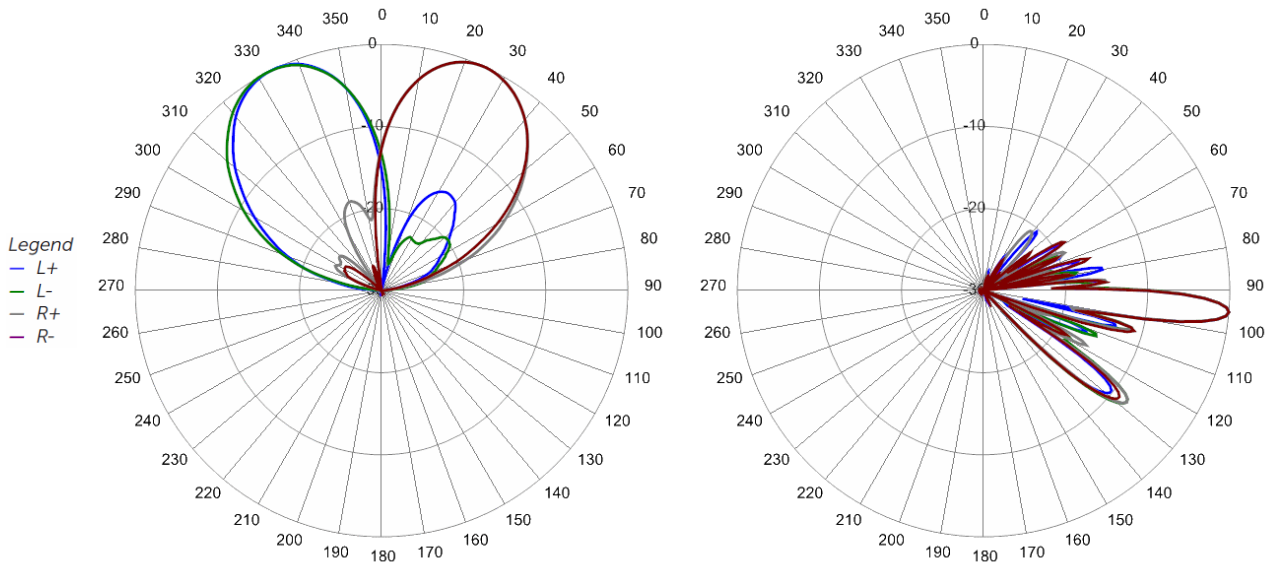

2345 MHz Azimuth Bi-Sector Ports

2345 MHz Elevation 5° Bi-Sector Ports

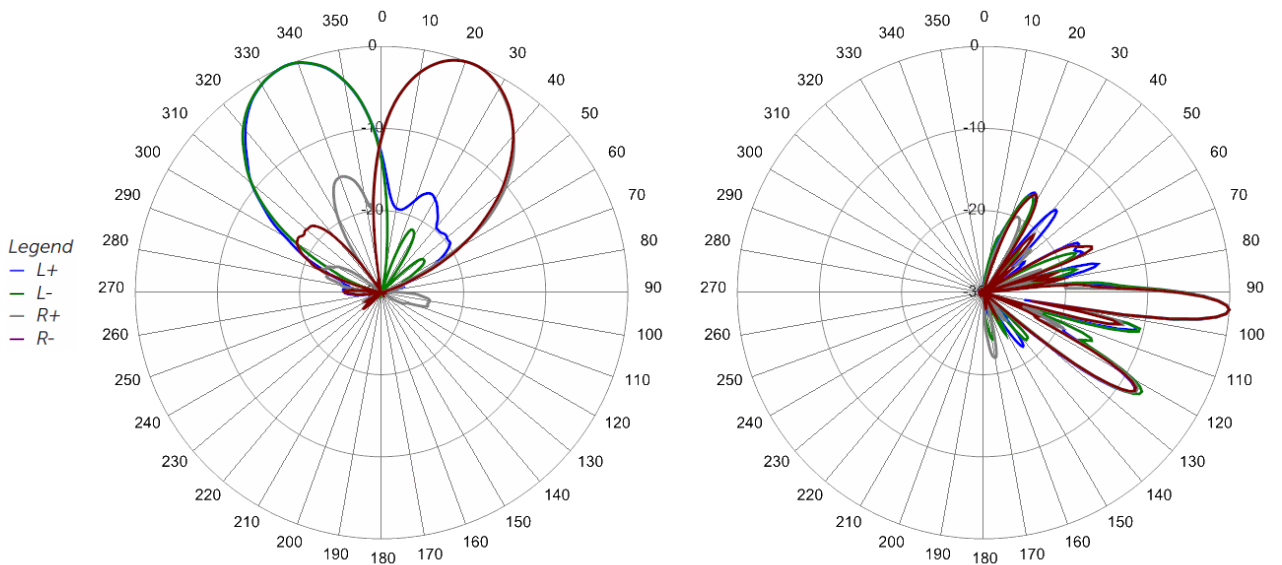

2650 MHz Azimuth Bi-Sector Ports

2650 MHz Elevation 5° Bi-Sector Ports



# Antennas

ORDERING

Hybrid Bi-Sector™ Array

HBSA33R-KE4A

Parts & Accessories

<b>HBSA33R-KE4AA-K</b>	Four foot (1.2 m) Hybrid Bi-Sector™ Antenna Array with 4.3-10 female connector, 3 factory installed external BSA-RET200 RET actuators (Type 1 External) and MBK-02 mounting brackets
<b>MBK-02</b>	Mounting bracket kit (top and bottom) with 0° to 10° mechanical tilt adjustment
<b>BSA-RET200</b>	Remote electrical tilt actuator
<b>HPA-CBK-AG-RRU</b>	RRU AISG cable kit for three RET antenna
<b>HPA-CBK-RA-AG-RRU</b>	RRU AISG right angle cable kit for three RET antenna



# Antennas

ACCESSORIES

## Mounting Bracket Kit

MBK-02

### Mechanical

<b>Weight</b>	9.8 lbs (4.4 kg)
<b>Hinge Pitch</b>	31.5 in (800 mm)
<b>Mounting Pole Dimension</b>	2 to 5 in (5 to 12 cm)
<b>Fastener Size</b>	M10
<b>Installation Torque</b>	15 ft·lbs (20 N·m)
<b>Mechanical Tilt Adjustment</b>	0° - 10°

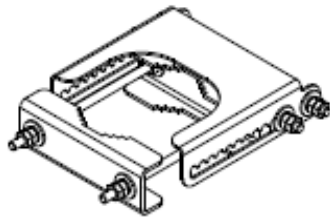

MBK-02 Top Adjustable Bracket

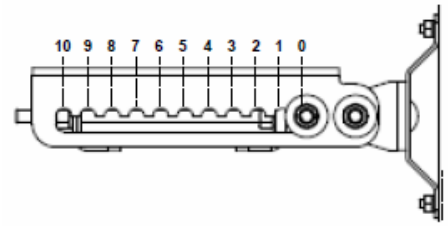

MBK-02 Top Adjustable Bracket Side View

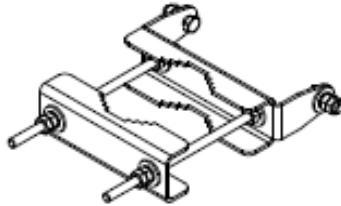

MBK-02 Bottom Fixed Bracket



# Antennas

ACCESSORIES

## Remote Electrical Tilt Actuator (RET)

BSA-RET200

### General Specifications

Part Number	BSA-RET200
Protocols	AISG 2.0
RET Type	Type 1
Adjustment Cycles	>10,000 cycles
Tilt Accuracy	±0.1°
Temperature Range	-40° C to 70° C

### Electrical

Data Interface Signal	DC
Input Voltage	10-30 Vdc
Current Consumption Tilt	120 mA at $V_{in}=24$
Current Consumption Idle	55 mA at $V_{in}=24$
Hardware Interface	AISG-RS 485 A/B
Input Connector	Male 1 × 8 pin Daisy Chain
Output Connector	Female 1 × 8 pin Daisy Chain

### Mechanical

Dimensions (LxWxD)	8.0x5.0x2.0 in. (213x135x51 mm)
Housing	ASA/ABS/Aluminum
Weight	1.7 lbs (0.75 kg)

ASA= Acrylic Styrene Acrylonitrile  
ABS=Acrylonitrile Butadiene Styrene

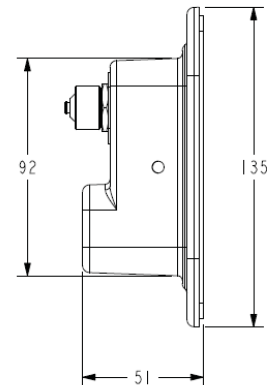
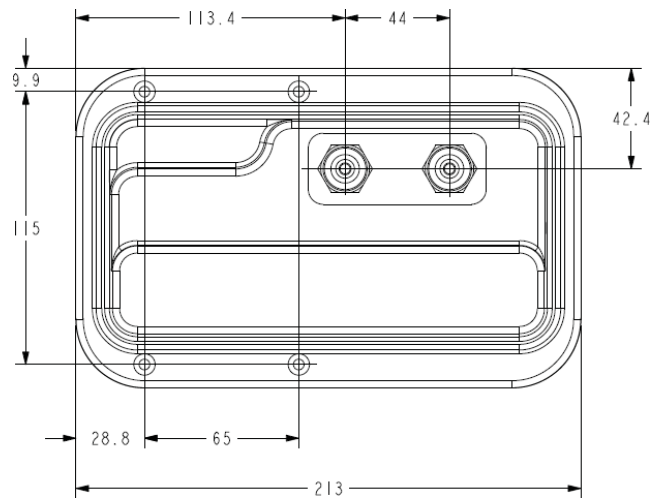



# Antennas

ACCESSORIES

AISG Cable Kit

HPA-CBK-AG-RRU

## Electrical Specifications

<b>Individual Cable Part Number</b>	AISGC-M-F-18	AISGC-M-F-10FT
<b>Cable style</b>	UL2464	UL2464
<b>Protocol</b>	AISG 1.1 and AISG 2.0	AISG 1.1 and AISG 2.0
<b>Maximum voltage</b>	300 V	300 V
<b>Rated current</b>	5 A at 104° F (40° C)	5 A at 104° F (40° C)

## Mechanical Specifications

<b>Individual Cable Part Number</b>	AISGC-M-F-18	AISGC-M-F-10FT
<b>Cables per kit</b>	2	2
<b>Connectors</b>	2 x 8 pin IEC 60130-9 Straight male/straight female	2 x 8 pin IEC 60130-9 Straight male/straight female
<b>Tightening torque</b>	Hand tighten only $\approx$ 1.84 ft-lbs (2.5 N-m)	Hand tighten only $\approx$ 1.84 ft-lbs (2.5 N-m)
<b>Construction</b>	Shielded (Tinned Copper Braid)	Shielded (Tinned Copper Braid)
<b>Braid coverage</b>	85%	85%
<b>Jacket Material</b>	Matte Polyurethane (Black)	Matte Polyurethane (Black)
<b>Conductors</b>	1 twisted pair - 24 AWG 3 conductors - 19 AWG AWM style 2464	1 twisted pair - 24 AWG 3 conductors - 19 AWG AWM style 2464
<b>Cable Diameter</b>	0.307 in (7.8 mm)	0.307 in (7.8 mm)
<b>Length</b>	18 - 20 in (457 - 508 mm)	120 in (3048 mm)
<b>Weight</b>	0.27 lbs (0.12 kg)	0.69 lbs (.31 kg)
<b>Minimum bend radius</b>	3.9 in (100 mm)	3.9 in (100 mm)

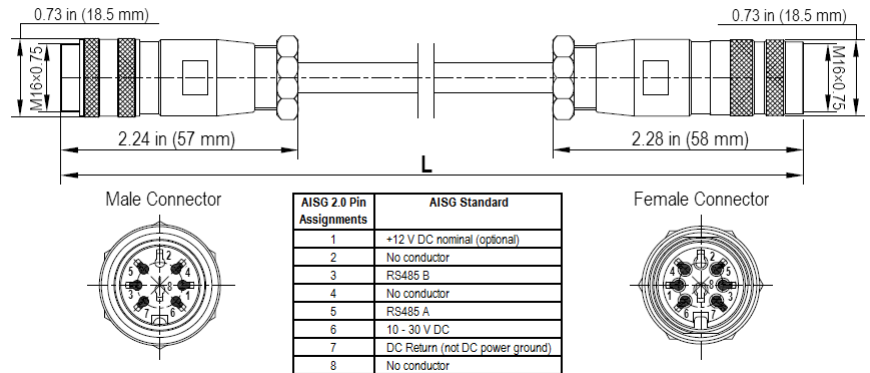

AISG-Male to AISG-Female Jumper Cable

## Environmental Specifications

<b>Individual Cable Part Number</b>	AISGC-M-F-18	AISGC-M-F-10FT
<b>Temperature Range</b>	-40° to 80° C	-40° to 80° C
<b>Flammability</b>	UL 1581 VW-1	UL 1581 VW-1
<b>Ingress Protection</b>	IEC 60529:2001, IP67	IEC 60529:2001, IP67



# Antennas

ACCESSORIES

AISG Cable Kit

HPA-CBK-RA-AG-RRU

## Electrical/Mechanical/Environmental Specifications

	RET to RET Cables	RRU to Antenna Cables
Individual Cable Part Number	AISGC-MRA-FRA-20	AISGC-M-FRA-10FT
Cable style	UL2464	
Protocol	AISG 1.1 and AISG 2.0	
Maximum voltage	300 V	
Rated current	5 A at 104° F (40° C)	
Temperature Range	-40° to 80° C	
Flammability	UL 1581 VW-1	
Ingress Protection	IEC 60529:2001, IP67	
Tightening torque	Hand tighten only $\approx$ 1.84 ft-lbs (2.5 N·m)	
Construction	Shielded (Tinned Copper Braid)	
Braid coverage	85%	
Jacket Material	Matte Polyurethane (Black)	
Conductors	1 twisted pair - 24 AWG 3 conductors - 19 AWG AWM style 2464	
Cable Diameter	0.307 in (7.8 mm)	
Minimum bend radius	3.9 in (100 mm)	
Connectors	2 x 8 pin IEC 60130-9 Right angle male/right angle female	2 x 8 pin IEC 60130-9 Straight male/right angle female
Length	20 in (508 mm)	120 in (3048 mm)
Weight	0.23 lbs (0.10 kg)	0.77 lbs (0.35 kg)
Cables per kit	2	2

## Mechanical Specifications

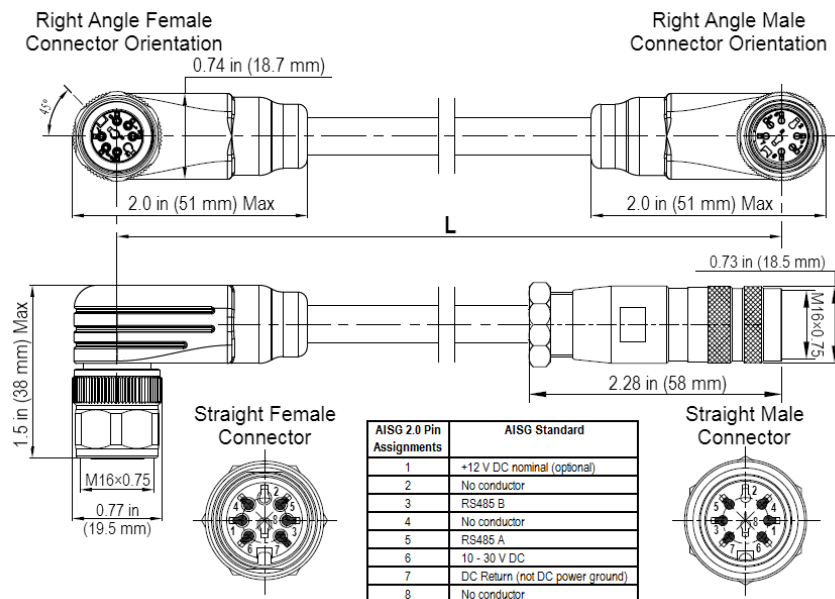

Right Angle to Right Angle and Right Angle to Straight Jumper Cable



# Antennas

## STANDARDS & CERTIFICATIONS

### Hybrid Bi-Sector™ Array

HBSA33R-KE4A

#### Standards & Compliance

<b>Safety</b>	EN 60950-1, UL 60950-1
<b>Emission</b>	EN 55022
<b>Immunity</b>	EN 55024
<b>Environmental</b>	IEC 60068-2-1, IEC 60068-2-2, IEC 60068-2-5, IEC 60068-2-6, IEC-60068-2-11, IEC 60068-2-14, IEC 60068-2-18, IEC 60068-2-27, IEC 60068-2-29, IEC 60068-02-30, IEC 60068-2-52, IEC 60068-2-64, GR-63-CORE 4.3.1, EN 60529, IP 24

#### Certifications

Antenna Interface Standards Group (AISG), Federal Communication Commission (FCC) Part 15 Class B, CE, CSA US, ISO 9001



# CCI

## Communication Components Inc.

EXTENDING WIRELESS PERFORMANCE