



Antennas

DATA SHEET

Wideband Bi-Sector™ Array

BSA-S65R-W-H5



- Five foot (1.4 m), four port, dual beam antenna with patented asymmetrical beam shapes optimized for LTE
- Two wideband 33° beams to match existing 65° patterns, covering 1710-2170 MHz
- One pair of +45° and -45° cross-polarized ports for each beam
- Slim and low weight single panel design supporting two beams in a single antenna
- Field replaceable, integrated AISG 2.0 compliant Remote Electrical Tilt (RET) system with independent tilt control for each beam
- Dramatic increase in site capacity through higher order sectorization which offsets the need to build new sites
- Boosts data throughput by minimizing interference and optimizing coverage
- Sharp elevation beamwidth aides in network planning
- Optimal elevation sidelobe performance
- Exceeds minimum PIM performance requirements

Overview

The CCI wideband Bi-Sector™ array is a dual beam antenna with full DCS, PCS, 2100 UMTS and AWS band coverage. With two pairs of wideband ports covering 1710-2170 MHz, this five foot (1.4 m) CCI Bi-Sector™ provides the capability to deploy two beams (sectors) in a single antenna. The antenna allows separate tilt control for each beam individually, enabling maximum flexibility in network deployment. This antenna is available in both a Remote Electrical Tilt (RET) and a Variable Electrical Tilt (VET) configuration.

CCI's unique patented bi-sector technology provides optimized overlap between the pairs of asymmetric beams, lowers soft handover losses in LTE, UMTS/HSPA+ and CDMA/EVDO systems, while minimizing interference between sectors. Fast roll-off of each of the outer beams and high front-to-back ratios ensure reduced interference. This patented approach enhances data transfer rates within LTE, UMTS and EVDO network sectors and addresses "hotspots" in mobile wireless operator networks.

The single panel design of the Bi-Sector™ Array offers the opportunity to reduce antenna count and directly replaces an existing 65° antenna without mount changes and avoids costly leasing and zoning changes. The enhanced coverage matches the existing sector footprint and minimizes the need for optimization and adjacent site changes, providing operators with significant CAPEX and OPEX cost savings.

CCI antennas are designed and produced to ISO 9001 certification standards for reliability and quality in our state-of-the-art manufacturing facilities.

Applications

- Delivers increased capacity and data-throughput for sites that are performance or capacity constrained
- Provides a higher level of spectrum reuse making it an ideal solution for spectrum limited markets
- Increase capacity without the need for new site builds or carrier adds and without using valuable spectrum resources
- Efficient use of spectrum makes it ideally suited for spectrum clearing and refarming



Antennas

SPECIFICATIONS

Wideband Bi-Sector™ Array

BSA-S65R-W-H5

Electrical

Ports	4 x High Band Ports for 1710-2170 MHz		
Frequency Range	1710-1880 MHz	1850-1990 MHz	1920-2170 MHz
Gain	18.3 dBi	19.4 dBi	19.5 dBi
Azimuth Beamwidth (-3dB)	36°	33°	31°
Elevation Beamwidth (-3dB)	7.2°	6.6°	6.3°
Electrical Downtilt	0° to 10°	0° to 10°	0° to 10°
Elevation Sidelobes (1st Upper)	< -18 dB	< -18 dB	< -18 dB
Front-to-Back Ratio @180°	> 35 dB	> 35 dB	> 35 dB
Front-to-Back Ratio over ± 20°	> 35 dB	> 35 dB	> 35 dB
Cross-Polar Discrimination (at Peak)	> 28 dB	> 28 dB	> 28 dB
Cross-Polar Discrimination (at -3dB)	> 22 dB	> 22 dB	> 22 dB
Cross-Polar Port-to-Port Isolation	> 30 dB	> 30 dB	> 30 dB
Voltage Standing Wave Ratio(VSWR)	< 1.4:1	< 1.4:1	< 1.4:1
Passive Intermodulation (2x20W)	≤ -150 dBc	≤ -150 dBc	≤ -150 dBc
Input Power Continuous Wave (CW)	300 watts	300 watts	300 watts
Polarization	Dual Pol 45°	Dual Pol 45°	Dual Pol 45°
Input Impedance	50 ohms	50 ohms	50 ohms
Lightning Protection	DC Ground	DC Ground	DC Ground

Mechanical

Dimensions (LxWxD)	54.3x12.9x6.2 in (1379x327x158 mm)
Survival Wind Speed	> 150 mph (> 241 kph)
Front Wind Load	159 lbs (706 N) @ 100 mph (161 kph)
Side Wind Load	88 lbs (389 N) @ 100 mph (161 kph)
Equivalent Flat Plate Area	6.2 ft² (0.6 m²)
Weight *	31.2 lbs (14.2 kg)
RET System Weight	3.3 lbs (1.5 kg)
Connector	4 x 7-16 DIN female
Mounting Pole	2 to 5 in (5 to 12 cm)

* Weight excludes mounting and RET



Antennas

Wideband Bi-Sector™ Array

BSA-S65R-W-H5

SPECIFICATIONS

Bottom View RET Model

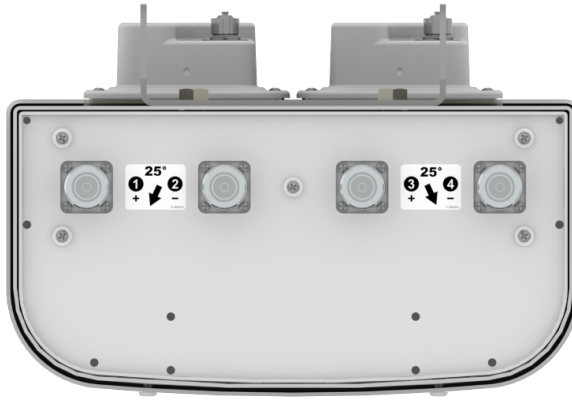

Rear View VET version



Mechanical

Connector Spacing

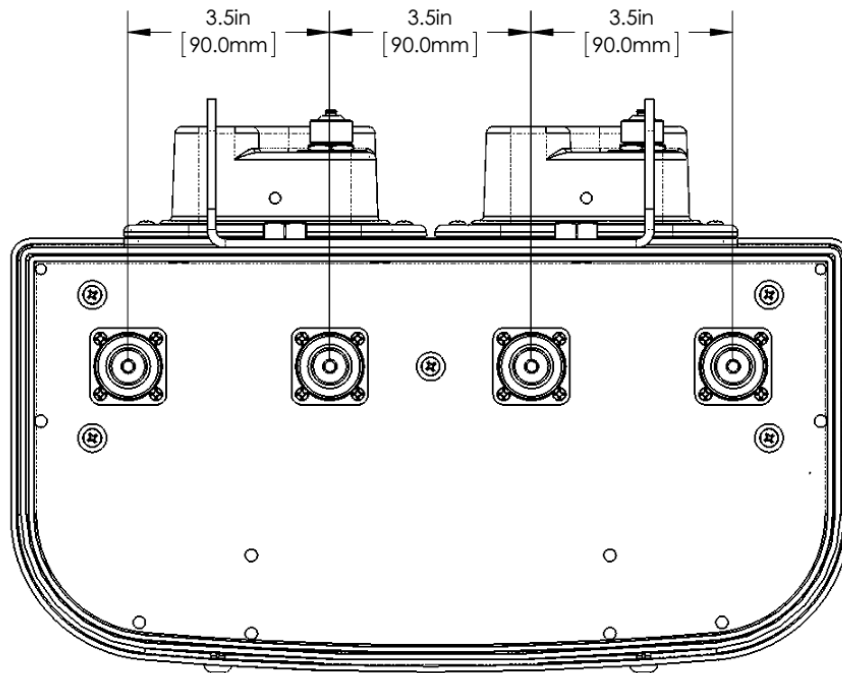



Antennas

SPECIFICATIONS

Wideband Bi-Sector™ Array

BSA-S65R-W-H5

Typical Antenna Patterns

For detailed information on additional antenna patterns, contact customer support at support@cciproducts.com

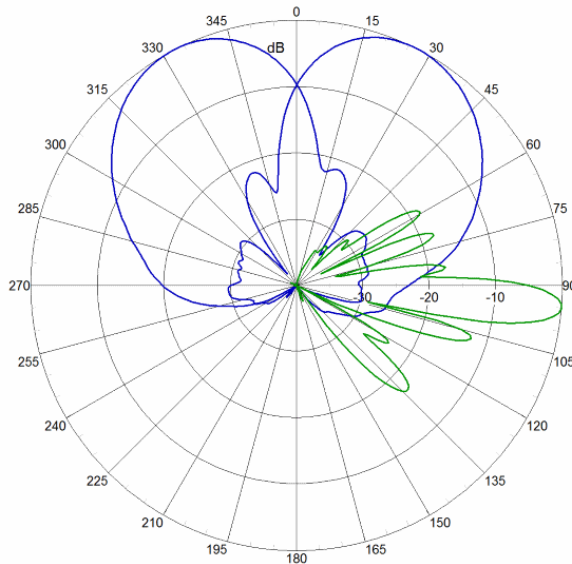

1755 MHz Azimuth Elevation 5°

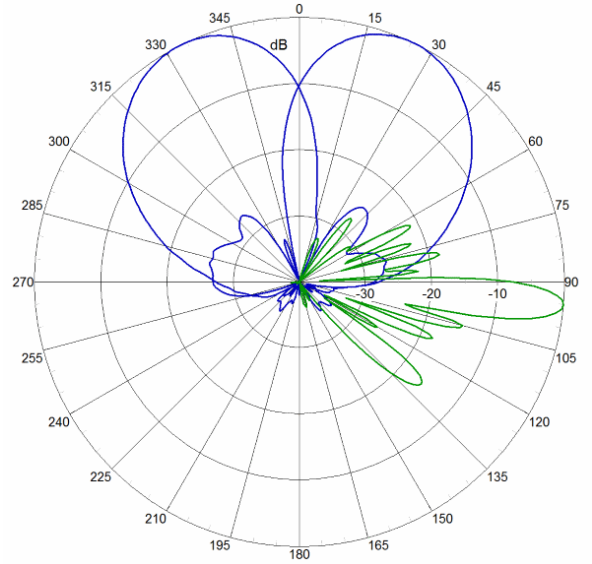

1930 MHz Azimuth Elevation 5°

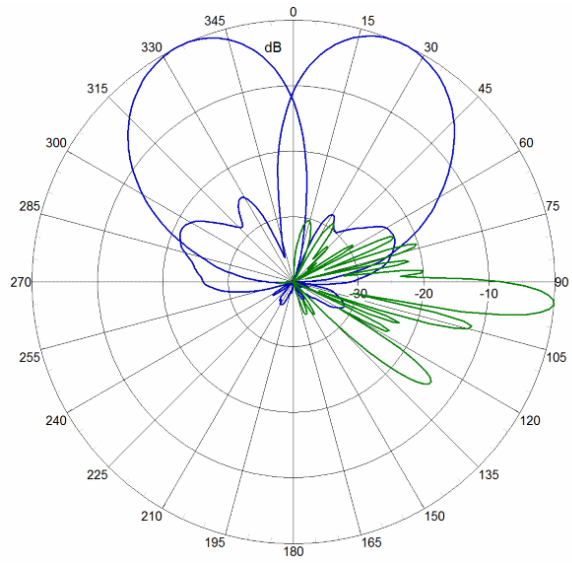

2110 MHz Azimuth Elevation 5°



Antennas

ORDERING

Wideband Bi-Sector™ Array

BSA-S65R-W-H5

Parts & Accessories

BSA-S65R-W-H5	Five foot (1.4 m) Bi-Sector™ array, Wideband (1800, 1900, 2110 MHz) and 2 factory installed BSA-RET200 RET actuators
BSA-S65V-W-H5	Five foot (1.4 m) Bi-Sector™ array, Wideband (1800, 1900, 2110 MHz), Variable Electrical Tilt
BSA-S65R-W-H5-K	Antenna kit with 2 factory installed RET actuators and MBK-02 mounting bracket
BSA-S65V-W-H5-K	Antenna kit with 2 factory installed VET actuators and MBK-02 mounting bracket
MBK-02	Mounting bracket kit (top and bottom) with 0° to 10° mechanical tilt adjustment
BSA-RET200	Remote electrical tilt actuator
QPA-CBK-AG-RRU	Quad Port antenna to RRU AISG cable kit
QPA-CBK-RA-AG-RRU	Quad Port antenna to RRU AISG right angle cable kit



Antennas

ACCESSORIES

Mounting Bracket Kit

MBK-02

Mechanical

Weight	9.8 lbs (4.4 kg)
Hinge Pitch	31.5 in (800 mm)
Mounting Pole Dimension	2 to 5 in (5 to 12 cm)
Fastener Size	M10
Installation Torque	15 ft·lbs (20 N·m)
Mechanical Tilt Adjustment	0° - 10°

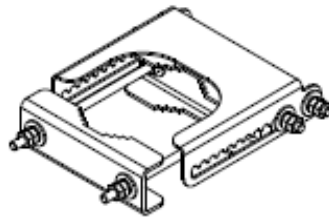

MBK-02 Top Adjustable Bracket

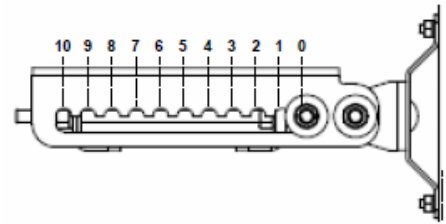

MBK-02 Top Adjustable Bracket Side View

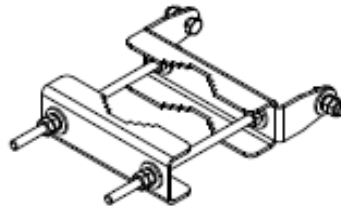

MBK-02 Bottom Fixed Bracket



Antennas

ACCESSORIES

Remote Electrical Tilt Actuator (RET)

BSA-RET200

General Specifications

Part Number	BSA-RET200
Protocols	AISG 2.0
RET Type	Type 1
Adjustment Cycles	>10,000 cycles
Tilt Accuracy	±0.1°
Temperature Range	-40° C to 70° C

Electrical

Data Interface Signal	DC
Input Voltage	10-30 Vdc
Current Consumption Tilt	120 mA at $V_{in}=24$
Current Consumption Idle	55 mA at $V_{in}=24$
Hardware Interface	AISG-RS 485 A/B
Input Connector	Male 1 × 8 pin Daisy Chain
Output Connector	Female 1 × 8 pin Daisy Chain

Mechanical

Dimensions (LxWxD)	8.0x5.0x2.0 in. (213x135x51 mm)
Housing	ASA/ABS/Aluminum
Weight	1.7 lbs (0.75 kg)

ASA= Acrylic Styrene Acrylonitrile
ABS=Acrylonitrile Butadiene Styrene

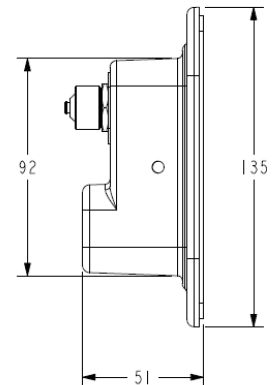
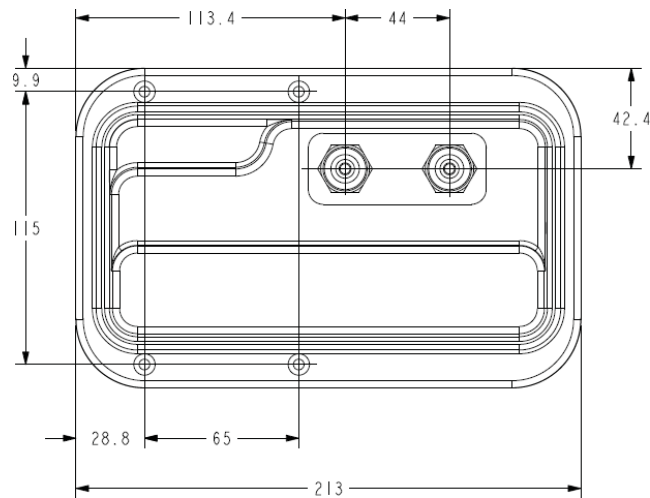



Antennas

ACCESSORIES

Quad Port AISG Cable Kit

QPA-CBK-AG-RRU

Electrical/Mechanical/Environmental Specifications

	RET to RET Cables	RRU to Antenna Cables
Individual Cable Part Number	AISGC-M-F-18	AISGC-M-F-10FT
Cable style	UL2464	
Protocol	AISG 1.1 and AISG 2.0	
Maximum voltage	300 V	
Rated current	5 A at 104° F (40° C)	
Temperature Range	-40° to 80° C	
Flammability	UL 1581 VW-1	
Ingress Protection	IEC 60529:2001, IP67	
Tightening torque	Hand tighten only ≈ 1.84 ft-lbs (2.5 N·m)	
Construction	Shielded (Tinned Copper Braid)	
Braid coverage	85%	
Jacket Material	Matte Polyurethane (Black)	
Conductors	1 twisted pair - 24 AWG 3 conductors - 19 AWG AWM style 2464	
Cable Diameter	0.307 in (7.8 mm)	
Minimum bend radius	3.9 in (100 mm)	
Connectors	2 x 8 pin IEC 60130-9 Straight male/straight female	
Length	18-20 in (457-508)	120 in (3048 mm)
Weight	0.27 lbs (0.12 kg)	0.69 lbs (0.31 kg)
Cables per kit	1	2

Mechanical Specifications

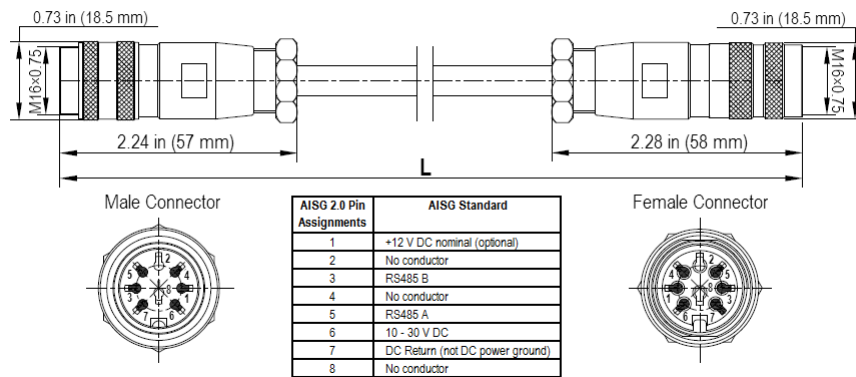

AISG-Male to AISG-Female Jumper Cable



Antennas

ACCESSORIES

Quad Port AISG Cable Kit

QPA-CBK-RA-AG-RRU

Electrical/Mechanical/Environmental Specifications

	RET to RET Cables	RRU to Antenna Cables
Individual Cable Part Number	AISGC-MRA-FRA-20	AISGC-M-FRA-10FT
Cable style	UL2464	
Protocol	AISG 1.1 and AISG 2.0	
Maximum voltage	300 V	
Rated current	5 A at 104° F (40° C)	
Temperature Range	-40° to 80° C	
Flammability	UL 1581 VW-1	
Ingress Protection	IEC 60529:2001, IP67	
Tightening torque	Hand tighten only \approx 1.84 ft-lbs (2.5 N·m)	
Construction	Shielded (Tinned Copper Braid)	
Braid coverage	85%	
Jacket Material	Matte Polyurethane (Black)	
Conductors	1 twisted pair - 24 AWG 3 conductors - 19 AWG AWM style 2464	
Cable Diameter	0.307 in (7.8 mm)	
Minimum bend radius	3.9 in (100 mm)	
Connectors	2 x 8 pin IEC 60130-9 Right angle male/right angle female	2 x 8 pin IEC 60130-9 Straight male/right angle female
Length	20 in (508 mm)	120 in (3048 mm)
Weight	0.23 lbs (0.10 kg)	0.77 lbs (0.35 kg)
Cables per kit	1	2

Mechanical Specifications

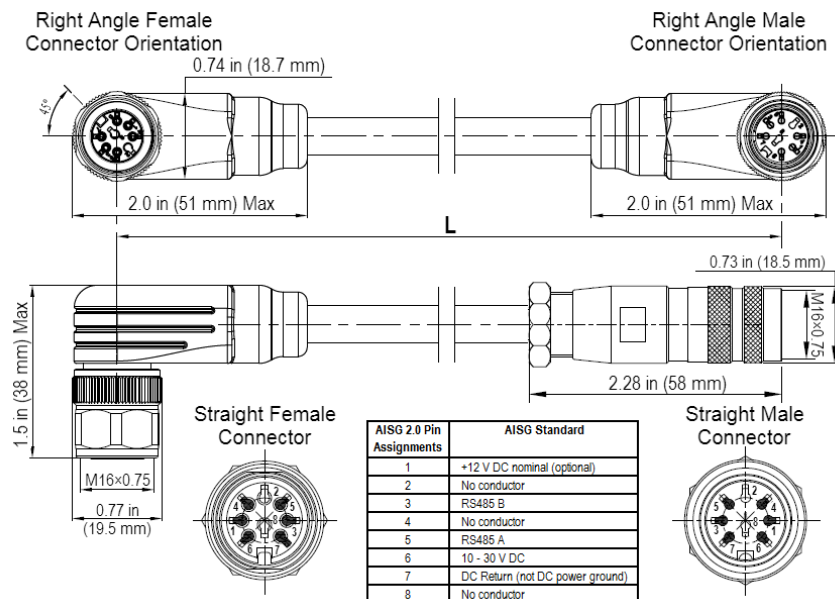

Right Angle to Right Angle and Right Angle to Straight Jumper Cable



Antennas

STANDARDS & CERTIFICATIONS

Wideband Bi-Sector™ Array

BSA-S65R-W-H5

Standards & Compliance

Safety	EN 60950-1, UL 60950-1
Emission	EN 55022
Immunity	EN 55024
Environmental	IEC 60068-2-1, IEC 60068-2-2, IEC 60068-2-5, IEC 60068-2-6, IEC-60068-2-11, IEC 60068-2-14, IEC 60068-2-18, IEC 60068-2-27, IEC 60068-2-29, IEC 60068-02-30, IEC 60068-2-52, IEC 60068-2-64, GR-63-CORE 4.3.1, EN 60529, IP 24

Certifications

Antenna Interface Standards Group (AISG), Federal Communication Commission (FCC) Part 15 Class B, CE, CSA US, ISO 9001



CCI Communication Components Inc.
EXTENDING WIRELESS PERFORMANCE