



Antennas

DATA SHEET

Antenna Hoisting Harness

AHH-03



- For QPA65R-W3BA antenna
- 4 mm thick steel
- RoHS Compliant weather resistant plating

Overview

Removable Hoisting Hook designed for the QPA65R-W3BA Integrated Radio Series.



Antennas

SPECIFICATIONS

Antenna Hoisting Harness

AHH-03

Mechanical Specifications

Weight 1.1 lbs (0.5 kg)

Mechanical Size 8.5x2.2x4.5 in (216x55x122 mm)

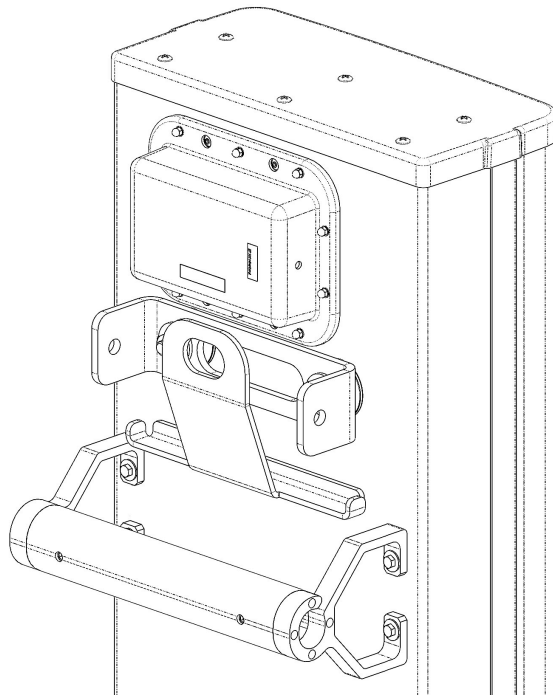

AHH-03 Installation

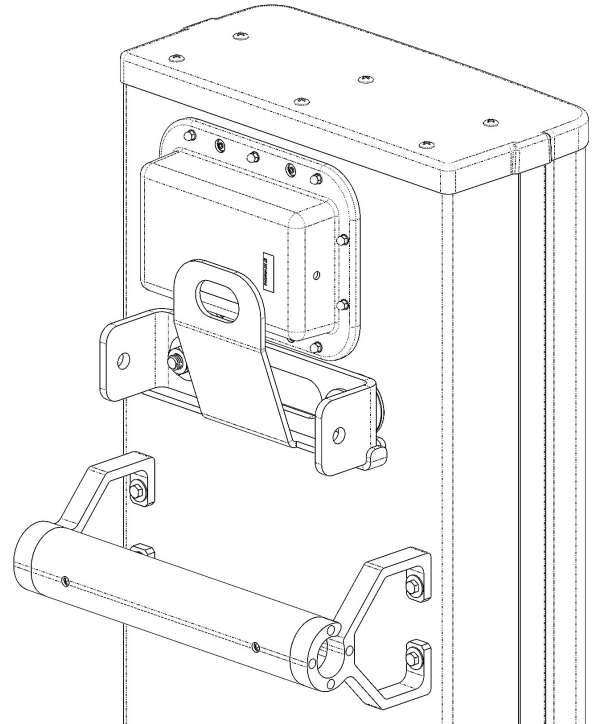

AHH-03 in Hoisting position

Individual Cable Part Number AHH-03

Construction A36 4mm Steel

Max Antenna weight 77.2 lbs (35.0 kg)

Environmental Specifications

Individual Part Number AHH-03

Temperature Range -45° to 70° C



Antennas

ORDERING

Antenna Hoisting Harness

AHH-03

Parts

AHH-03 Antenna Hoisting Hook for 3 foot (930 mm) QPA65R-W3BA